

LECTURE 21 – OUTPUT AMPLIFIERS

LECTURE ORGANIZATION

Outline

- Introduction
- Class A Amplifiers
- Push-Pull Amplifiers
- Bipolar Junction Transistor Output Amplifiers
- Using Negative Feedback to Reduce the Output Resistance
- Summary

CMOS Analog Circuit Design, 3rd Edition Reference

Pages 236-247

INTRODUCTION

General Considerations of Output Amplifiers

Requirements:

- 1.) Provide sufficient output power in the form of voltage or current.
- 2.) Avoid signal distortion.
- 3.) Be efficient
- 4.) Provide protection from abnormal conditions (short circuit, over temperature, etc.)

Types of Output Amplifiers:

- 1.) Class A amplifiers
- 2.) Source followers
- 3.) Push-pull amplifiers
- 4.) Substrate BJT amplifiers
- 5.) Amplifiers using negative shunt feedback

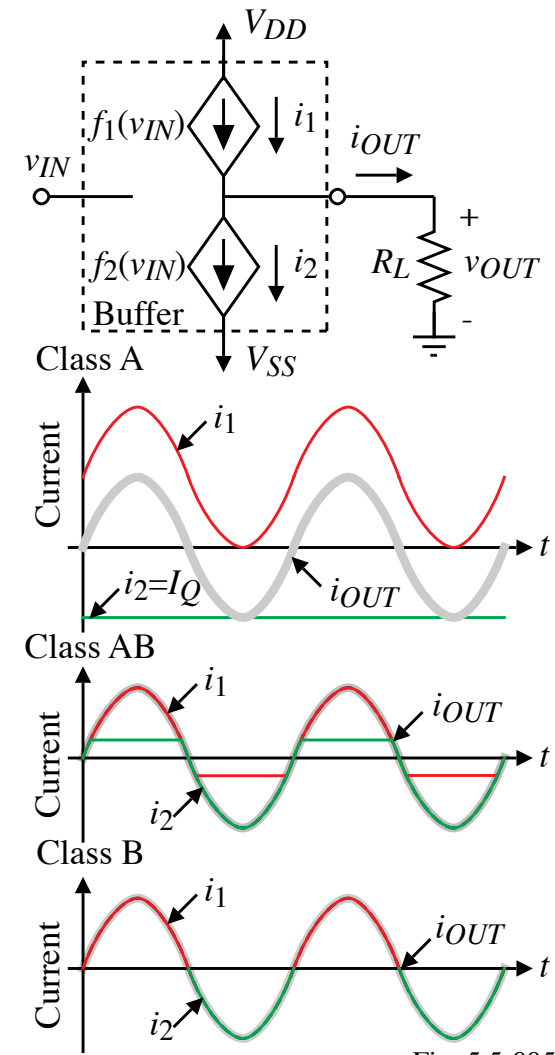
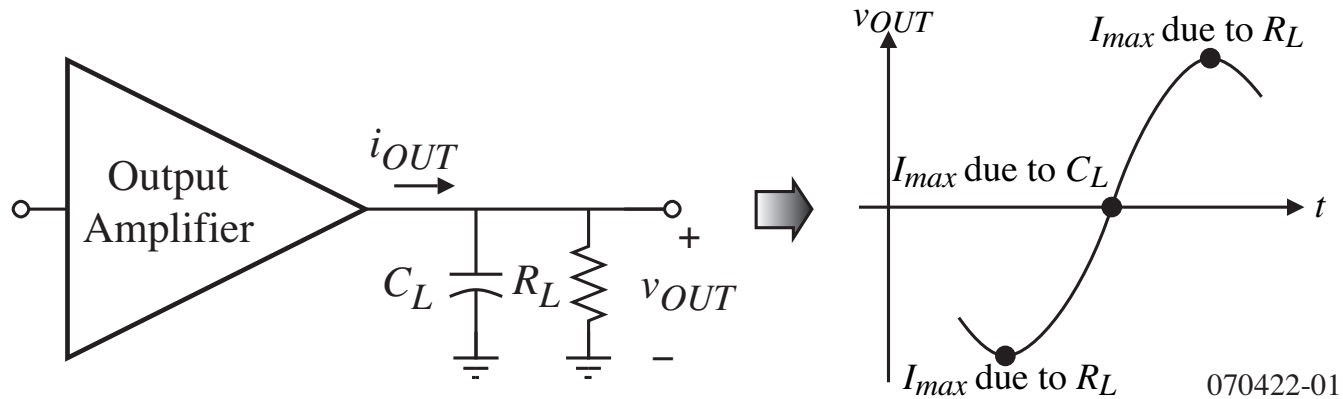

Fig. 5.5-005

Output Current Requirements for an Output Amplifier

Consider the current requirements placed by the load on the output amplifier:



Result:

$$|i_{OUT}| > C_L \cdot SR$$

$$|i_{OUT}| > \frac{v_{OUT}(\text{peak})}{R_L}$$

Fortunately, the maximum current for the resistor and capacitor do not occur at the same time.

Output Resistance Requirements for an Output Amplifier

In order to avoid attenuation of the amplifier voltage signal, the output resistance of the amplifier must be less than the load resistance.

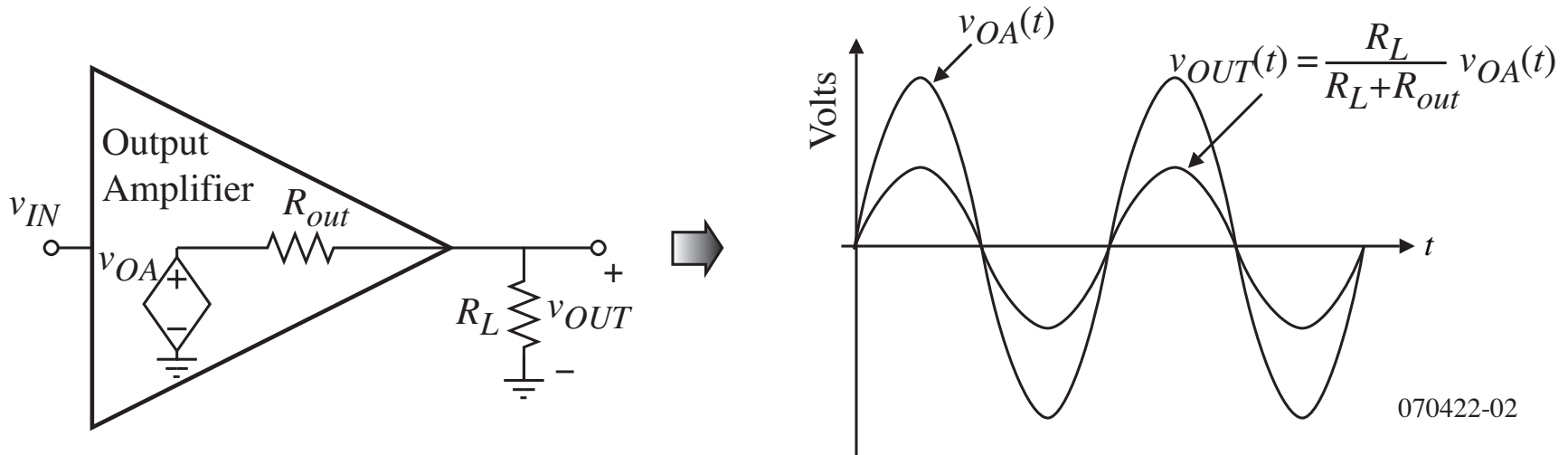

To avoid attenuation of the amplifier voltage signal, $R_{out} \ll R_L$.

Separation of the Amplifier Bias from the Load Resistance

Unfortunately, when a low load resistance is connected to the output of an amplifier, the bias conditions can be changed.

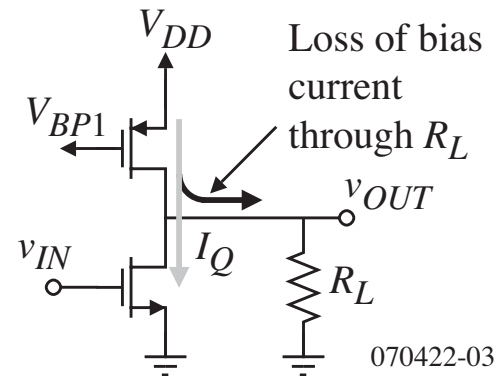

Solution:

- 1.) Use a coupling capacitance for singled-ended power supplies.
- 2.) Redefine the output analog ground as ($V_{DD}/2$).
- 3.) Use dc coupling for split power supplies.

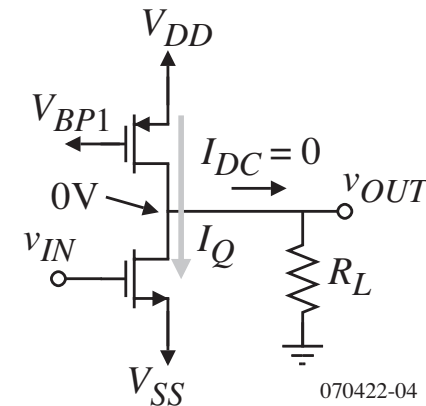
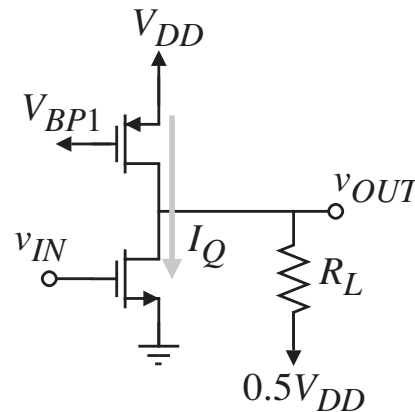
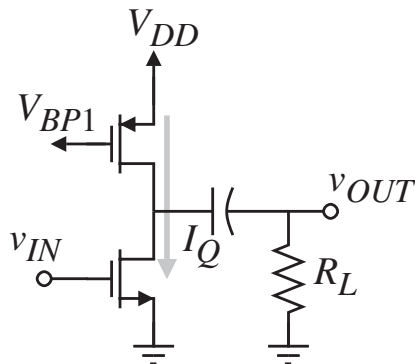

CLASS A AMPLIFIERS

Current source load inverter

A Class A circuit has current flow in the MOSFETs during the entire period of a sinusoidal signal.

Characteristics of Class A amplifiers:

- Unsymmetrical sinking and sourcing
- Linear
- Poor efficiency

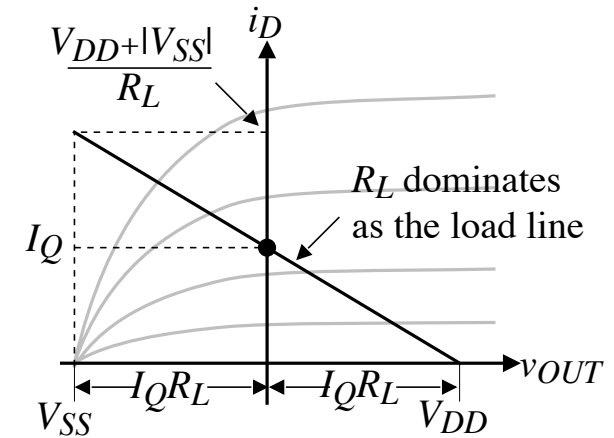
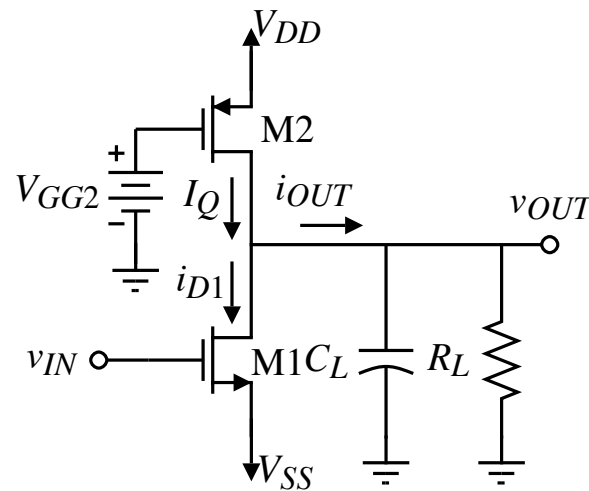

Fig. 5.5-1

$$\text{Efficiency} = \frac{P_{RL}}{P_{Supply}} = \frac{\frac{v_{OUT(\text{peak})}^2}{2R_L}}{(V_{DD}-V_{SS})I_Q} = \frac{\frac{v_{OUT(\text{peak})}^2}{2R_L}}{(V_{DD}-V_{SS})\left(\frac{(V_{DD}-V_{SS})}{2R_L}\right)} = \left(\frac{v_{OUT(\text{peak})}}{V_{DD}-V_{SS}}\right)^2$$

Maximum efficiency occurs when $v_{OUT(\text{peak})} = V_{DD} = |V_{SS}|$ which gives 25%.

Small-Signal Performance of the Class A Amplifier

Although we have considered the small-signal performance of the Class A amplifier as the current source load inverter, let us include the influence of the load.

The modified small-signal model:

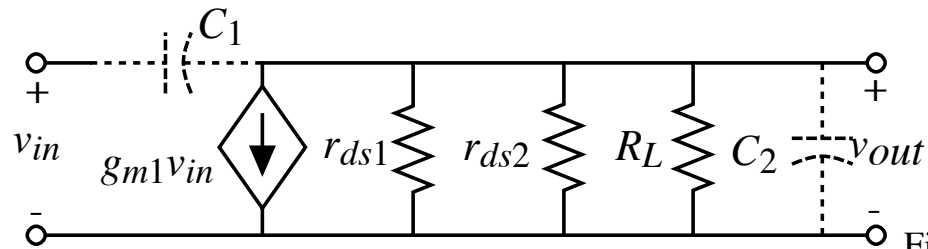

Fig. 5.5-2

The small-signal voltage gain is:

$$\frac{v_{out}}{v_{in}} = \frac{-g_{m1}}{g_{ds1} + g_{ds2} + G_L}$$

The small-signal frequency response includes:

A zero at

$$z = \frac{g_{m1}}{C_{gd1}}$$

and a pole at

$$p = \frac{-(g_{ds1} + g_{ds2} + G_L)}{C_{gd1} + C_{gd2} + C_{bd1} + C_{bd2} + C_L}$$

Example 21-1 - Design of a Simple Class-A Output Stage

Assume that $K_N' = 2K_P' = 100 \mu\text{A}/\text{V}^2$, $V_{TN} = 0.5\text{V}$ and $V_{TP} = -0.5\text{V}$. Design the W/L ratios of M1 and M2 so that a voltage swing of $\pm 1\text{V}$ and a slew rate of $\approx 1 \text{ V}/\mu\text{s}$ is achieved if $R_L = 1 \text{ k}\Omega$ and $C_L = 1000 \text{ pF}$. Assume $V_{DD} = |V_{SS}| = 2\text{V}$ and $V_{GG2} = 0\text{V}$. Let $L = 1 \mu\text{m}$ and assume that $C_{gd1} = 100\text{fF}$. Find the voltage gain and roots of this output amplifier.

Solution

Let us first consider the effects of R_L and C_L .

$$i_{OUT(\text{peak})} = \pm 1\text{V}/1\text{k}\Omega = \pm 1000\mu\text{A} \quad \text{and} \quad C_L \cdot SR = 10^{-9} \cdot 10^6 = 1000\mu\text{A}$$

Since the current for C_L and R_L occur at different times, choose a bias current of 1mA .

$$\frac{W_1}{L_1} = \frac{2(I_{OUT} + I_Q)}{K_N'(V_{DD} + |V_{SS}| - V_{TN})^2} = \frac{4000}{100 \cdot (3.5)^2} \approx \frac{3\mu\text{m}}{1\mu\text{m}}$$

and

$$\frac{W_2}{L_2} = \frac{2I_{OUT}^+}{K_P'(V_{DD} - V_{GG2} - |V_{TP}|)^2} = \frac{2000}{50 \cdot (1.5)^2} \approx \frac{18\mu\text{m}}{1\mu\text{m}}$$

The small-signal performance is $A_v = -0.775 \text{ V}/\text{V}$.

The roots are, zero = $g_{m1}/C_{gd1} \Rightarrow 1.23\text{GHz}$ and pole $\approx 1/(R_L C_L) \Rightarrow -159.15 \text{ kHz}$

Broadband Harmonic Distortion

The linearity of an amplifier can be characterized by its influence on a pure sinusoidal input signal. Assume the input is,

$$V_{in}(\omega) = V_p \sin(\omega t)$$

The output of an amplifier with distortion will be

$$V_{out}(\omega) = a_1 V_p \sin(\omega t) + a_2 V_p \sin(2\omega t) + \dots + a_n V_p \sin(n\omega t)$$

Harmonic distortion (HD) for the i th harmonic can be defined as the ratio of the magnitude of the i th harmonic to the magnitude of the fundamental.

For example, second-harmonic distortion would be given as

$$HD_2 = \frac{a_2}{a_1}$$

Total harmonic distortion (THD) is defined as the square root of the ratio of the sum of all of the second and higher harmonics to the magnitude of the first or fundamental

Thus, *THD* can be expressed as
$$THD = \frac{[a_2^2 + a_3^2 + \dots + a_n^2]^{1/2}}{a_1}$$

The distortion of the class A amplifier is good for small signals and becomes poor at maximum output swings because of the nonlinearity of the voltage transfer curve for large-signal swings.

Class-A Source Follower

The class-A source follower has lower output resistance and less attenuation of the amplifier voltage signal.

N-Channel Source Follower
with current sink bias:

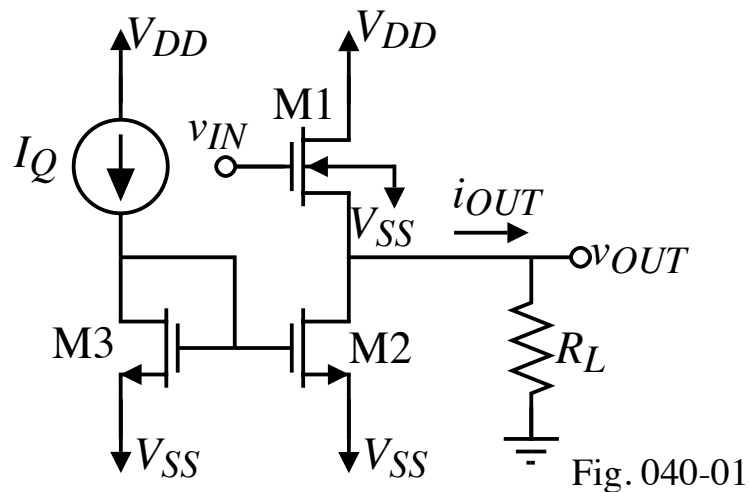

Voltage transfer curve:

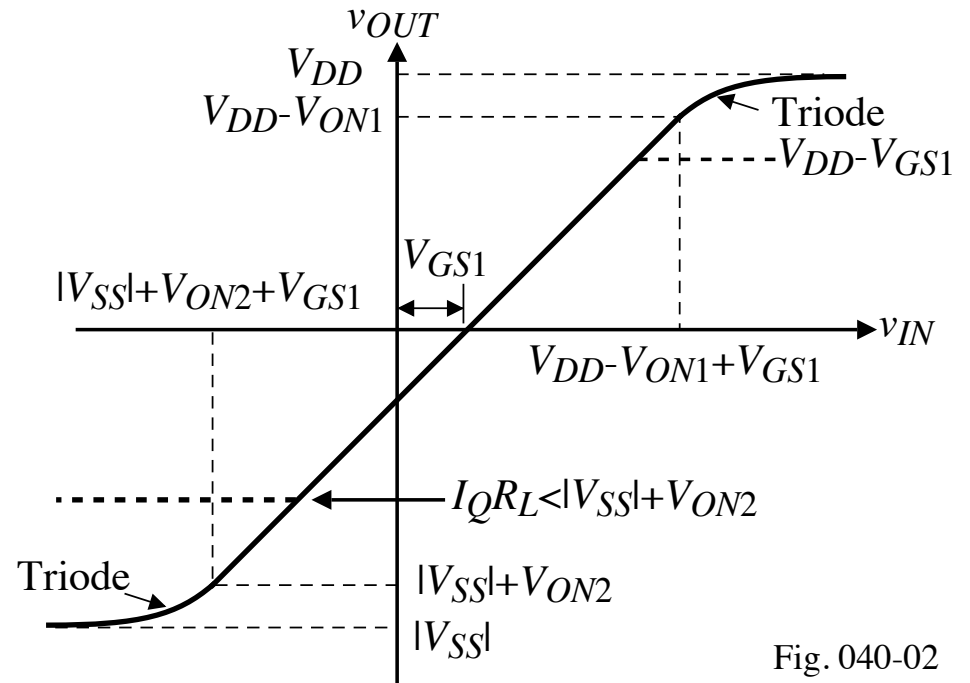

Maximum output voltage swings:

$$v_{OUT(\min)} \approx V_{SS} - V_{ON2} \text{ (if } R_L \text{ is large)}$$

$$\text{or } v_{OUT(\min)} \approx -I_Q R_L \text{ (if } R_L \text{ is small)}$$

$$v_{OUT(\max)} = V_{DD} - V_{ON1} \text{ (if } v_{IN} > V_{DD})$$

$$\text{or } v_{OUT(\max)} \approx V_{DD} - V_{GS1}$$

Output Voltage Swing of the Follower

The previous results do not include the bulk effect on V_{T1} of V_{GS1} .

Therefore,

$$V_{T1} = V_{T01} + \gamma[\sqrt{2|\phi_F| - v_{BS}} - \sqrt{2|\phi_F|}] \approx V_{T01} + \gamma\sqrt{v_{SB}} = V_{T01} + \gamma_1\sqrt{v_{OUT}(\max) - V_{SS}}$$

$$\therefore v_{OUT}(\max) - V_{SS} \approx V_{DD} - V_{SS} - V_{ON1} - V_{T1} = V_{DD} - V_{SS} - V_{ON1} - V_{T01} - \gamma_1\sqrt{v_{OUT}(\max) - V_{SS}}$$

Define $v_{OUT}(\max) - V_{SS} = v_{OUT}'(\max)$

which gives the quadratic,

$$v_{OUT}'(\max) + \gamma_1\sqrt{v_{OUT}'(\max) - (V_{DD} - V_{SS} - V_{ON1} - V_{T01})} = 0$$

Solving the quadratic gives,

$$v_{OUT}'(\max) \approx \frac{\gamma_1^2}{4} - \frac{\gamma_1}{2}\sqrt{\gamma_1^2 + 4(V_{DD} - V_{SS} - V_{ON1} - V_{T01})} + \frac{\gamma_1^2 + 4(V_{DD} - V_{SS} - V_{ON1} - V_{T01})}{4}$$

If $V_{DD} = 2.5\text{V}$, $\gamma_N = 0.4\text{V}^{1/2}$, $V_{TN1} = 0.7\text{V}$, and $V_{ON1} = 0.2\text{V}$, then $v_{OUT}'(\max) = 3.661\text{V}$

and

$$v_{OUT}(\max) = 3.661 - 2.5 = 1.161\text{V}$$

Maximum Sourcing and Sinking Currents for the Source Follower

Maximum Sourcing Current (into a short circuit):

We assume that the transistors are in saturation and $V_{DD} = -V_{SS} = 2.5V$, thus

$$I_{OUT}(\text{sourcing}) = \frac{K'_1 W_1}{2L_1} [V_{DD} - v_{OUT} - V_{T1}]^2 - I_Q$$

where v_{IN} is assumed to be equal to V_{DD} .

If $W_1/L_1 = 10$ and if $v_{OUT} = 0V$, then

$$V_{T1} = 1.08V \Rightarrow I_{OUT} \text{ equal to } 1.11 \text{ mA.}$$

However, as v_{OUT} increases above $0V$, the current rapidly decreases.

Maximum Sinking Current:

For the current sink load, the sinking current is limited by the bias current.

$$I_{OUT}(\text{sinking}) = I_Q$$

Efficiency of the Class A, source follower:

Same as the Class A, common source which is 25% maximum efficiency

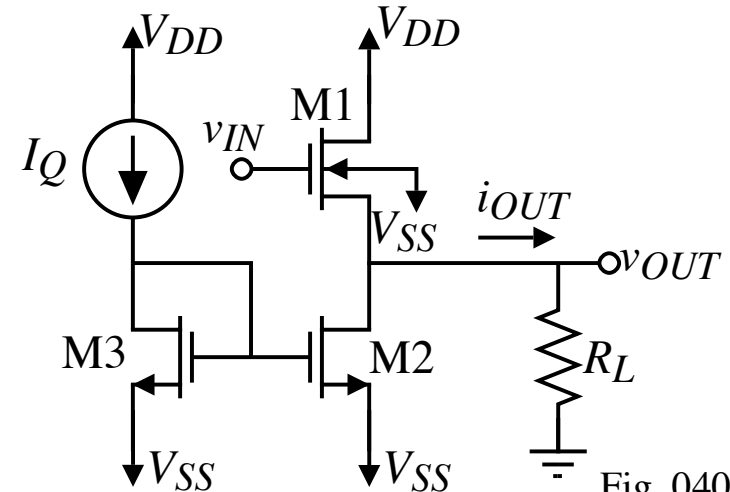

Fig. 040-01

Small Signal Performance of the Source Follower

Small-signal model:

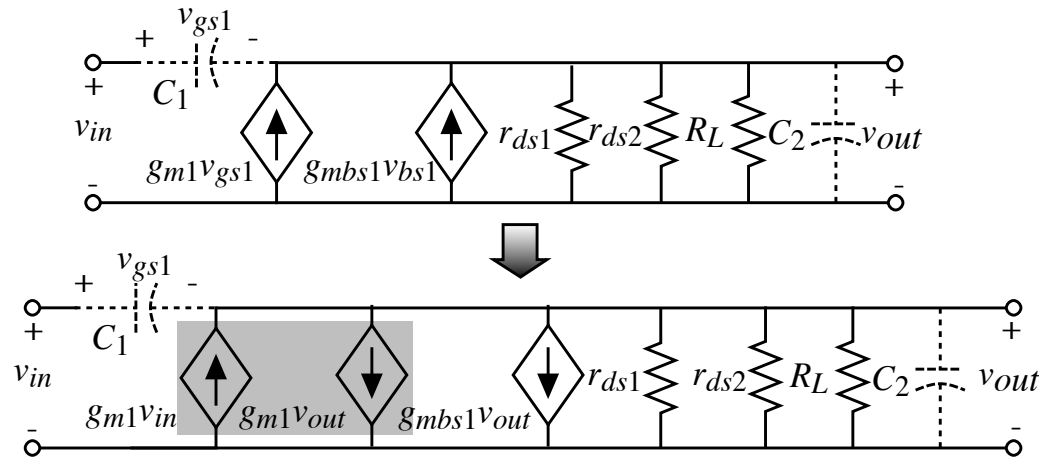

Fig. 040-04

$$\frac{V_{out}}{V_{in}} = \frac{g_{m1}}{g_{ds1} + g_{ds2} + g_{m1} + g_{mbs1} + G_L} \cong \frac{g_{m1}}{g_{m1} + g_{mbs1} + G_L} \cong \frac{g_{m1}R_L}{1 + g_{m1}R_L}$$

If $V_{DD} = -V_{SS} = 2.5\text{V}$, $V_{out} = 0\text{V}$, $W_1/L_1 = 10\mu\text{m}/1\mu\text{m}$, $W_2/L_2 = 1\mu\text{m}/1\mu\text{m}$, and $I_D = 500\mu\text{A}$, then:

For the current sink load follower ($R_L = \infty$):

$$\frac{V_{out}}{V_{in}} = 0.869\text{V/V}, \text{ if the bulk effect were ignored, then } \frac{V_{out}}{V_{in}} = 0.963\text{V/V}$$

For a finite load, $R_L = 1000\Omega$:

$$\frac{V_{out}}{V_{in}} = 0.512\text{V/V}$$

Small Signal Performance of the Source Follower - Continued

The output resistance is:

$$R_{out} = \frac{1}{g_{m1} + g_{mbs1} + g_{ds1} + g_{ds2}}$$

For the current sink load follower:

$$R_{out} = 830\Omega$$

The frequency response of the source follower:

$$\frac{V_{out}(s)}{V_{in}(s)} = \frac{(g_{m1} + sC_1)}{g_{ds1} + g_{ds2} + g_{m1} + g_{mbs1} + G_L + s(C_1 + C_2)}$$

where

$C_1 =$ capacitances connected between the input and output $\approx C_{GS1}$

$C_2 = C_{bs1} + C_{bd2} + C_{gd2}$ (or C_{gs2}) $+ C_L$

$$z = -\frac{g_{m1}}{C_1} \quad \text{and} \quad p \approx -\frac{g_{m1} + G_L}{C_1 + C_2}$$

The presence of a LHP zero leads to the possibility that in most cases the pole and zero will provide some degree of cancellation leading to a broadband response.

PUSH-PULL AMPLIFIERS

Push-Pull Source Follower

Can both sink and source current and provide a slightly lower output resistance.

Efficiency:

Depends on how the transistors are biased.

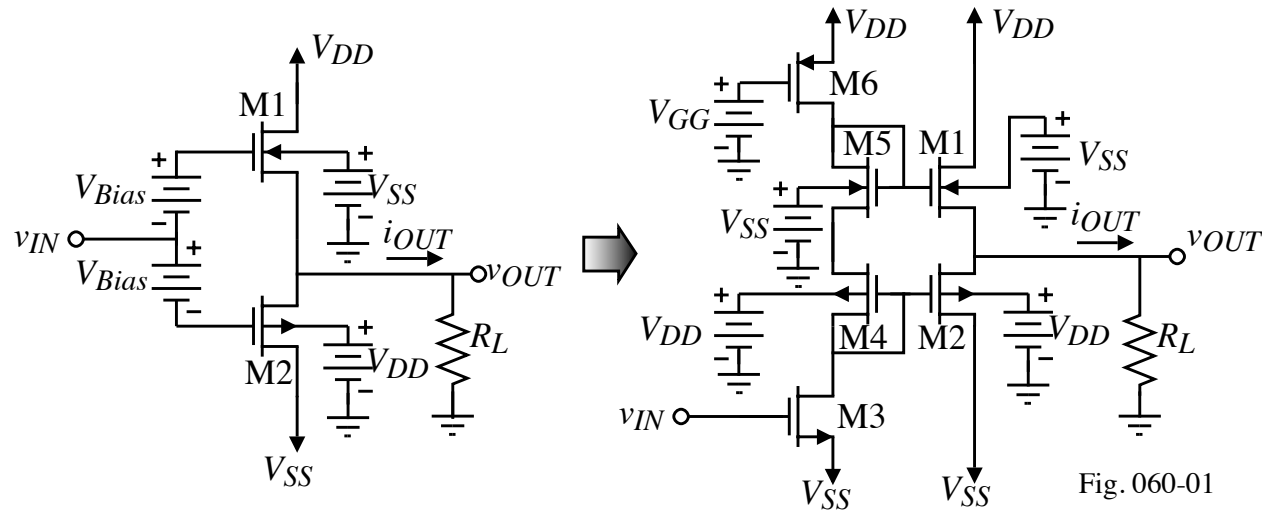

- Class B - one transistor has current flow for only 180° of the sinusoid (half period)

$$\therefore \text{Efficiency} = \frac{P_{RL}}{P_{VDD}} = \frac{\frac{v_{OUT(\text{peak})}^2}{2R_L}}{(V_{DD} - V_{SS}) \left(\frac{1}{2} \right) \left(\frac{2v_{OUT(\text{peak})}}{\pi R_L} \right)} = \frac{\pi}{2} \frac{v_{OUT(\text{peak})}}{V_{DD} - V_{SS}}$$

Maximum efficiency occurs when $v_{OUT(\text{peak})} = V_{DD}$ and is 78.5%

- Class AB - each transistor has current flow for more than 180° of the sinusoid.

Maximum efficiency is between 25% and 78.5%

Illustration of Class B and Class AB Push-Pull, Source Follower

Output current and voltage characteristics of the push-pull, source follower ($R_L = 1k\Omega$):

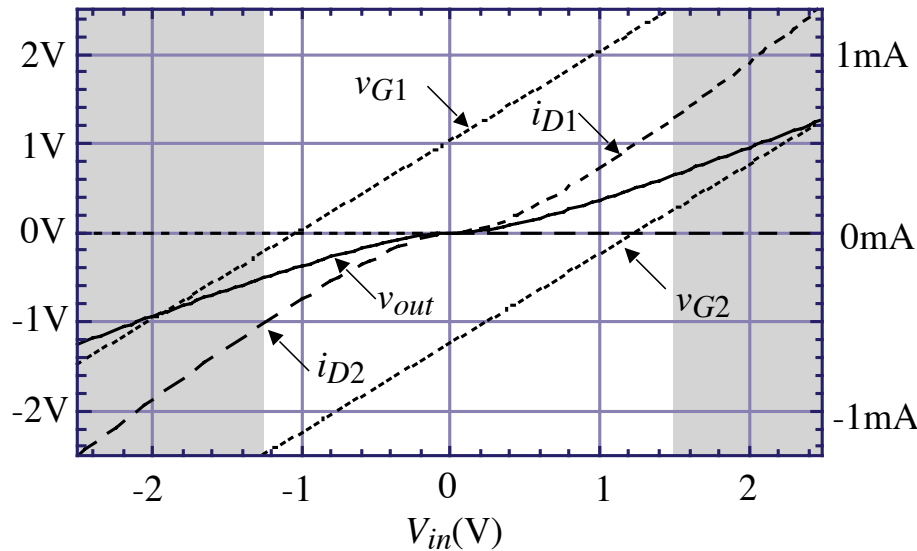

Class B, push-pull, source follower

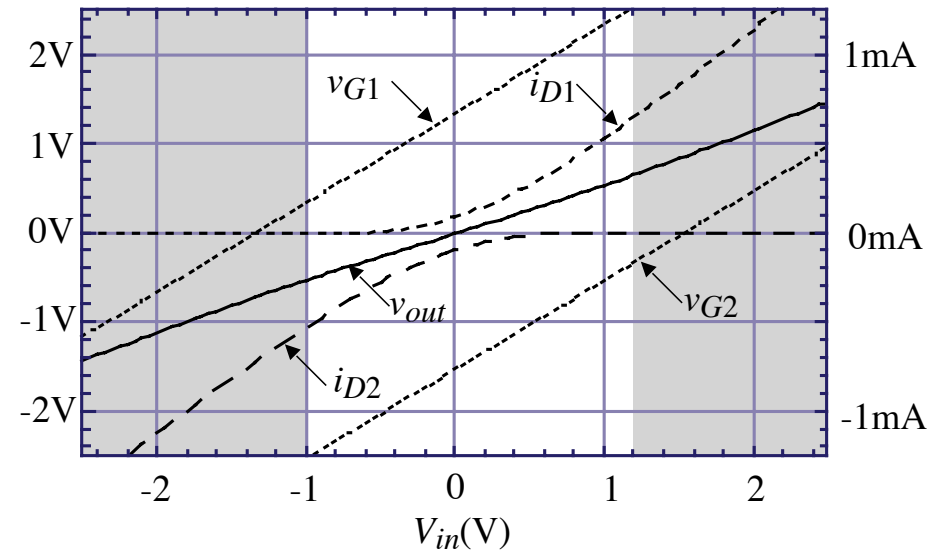

Class AB, push-pull, source follower

Fig. 060-02

Comments:

- Note that v_{OUT} cannot reach the extreme values of V_{DD} and V_{SS}
- $I_{OUT}^+(\text{max})$ and $I_{OUT}^-(\text{max})$ is always less than V_{DD}/R_L or V_{SS}/R_L
- For $v_{OUT} = 0V$, there is quiescent current flowing in M1 and M2 for Class AB
- Note that there is significant distortion at $v_{IN} = 0V$ for the Class B push-pull follower

Small-Signal Performance of the Push-Pull Follower

Model:

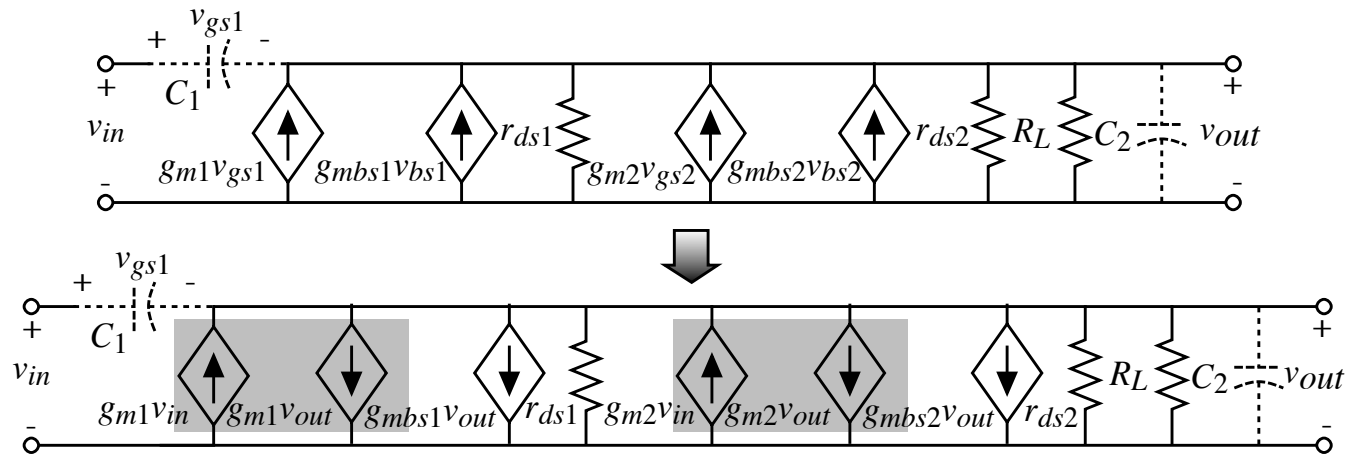

Fig. 060-03

$$\frac{v_{out}}{v_{in}} = \frac{g_{m1} + g_{m2}}{g_{ds1} + g_{ds2} + g_{m1} + g_{mbs1} + g_{m2} + g_{mbs2} + G_L}$$

$$R_{out} = \frac{1}{g_{ds1} + g_{ds2} + g_{m1} + g_{mbs1} + g_{m2} + g_{mbs2}} \quad (\text{does not include } R_L)$$

If $V_{DD} = -V_{SS} = 2.5\text{V}$, $V_{out} = 0\text{V}$, $I_{D1} = I_{D2} = 500\mu\text{A}$, and $W/L = 20\mu\text{m}/2\mu\text{m}$, $A_v = 0.787$ ($R_L = \infty$) and $R_{out} = 448\Omega$.

A zero and pole are located at

$$z = \frac{-(g_{m1} + g_{m2})}{C_1} \quad \text{and} \quad p = \frac{-(g_{ds1} + g_{ds2} + g_{m1} + g_{mbs1} + g_{m2} + g_{mbs2} + G_L)}{C_1 + C_2}$$

These roots will be at high frequencies because the associated resistances are small.

Push-Pull, Common Source Amplifiers

Similar to the class A but can operate as class B providing higher efficiency.

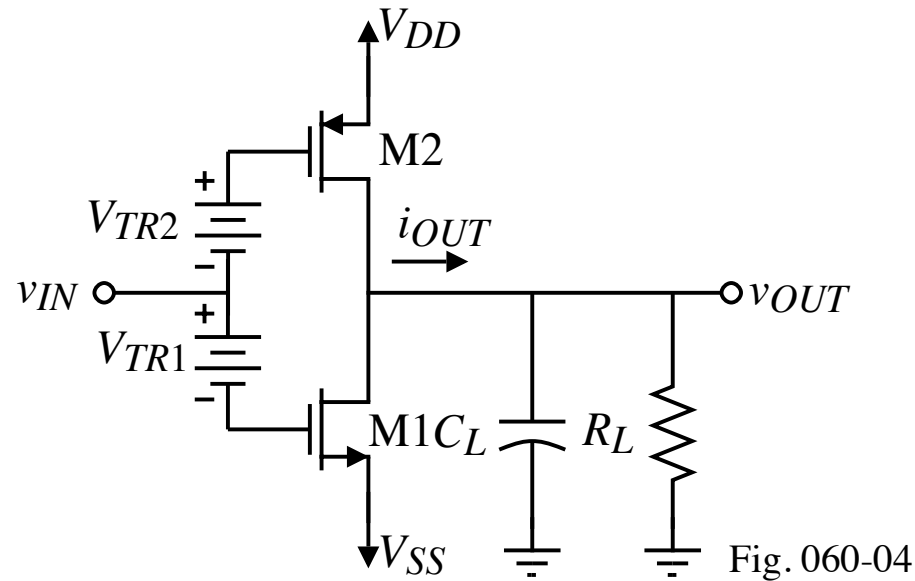

Comments:

- The batteries V_{TR1} and V_{TR2} are necessary to control the bias current in M1 and M2.
- The efficiency is the same as the push-pull, source follower.

Illustration of Class B and Class AB Push-Pull, Inverting Amplifier

Output current and voltage characteristics of the push-pull, inverting amplifier ($R_L = 1\text{k}\Omega$):

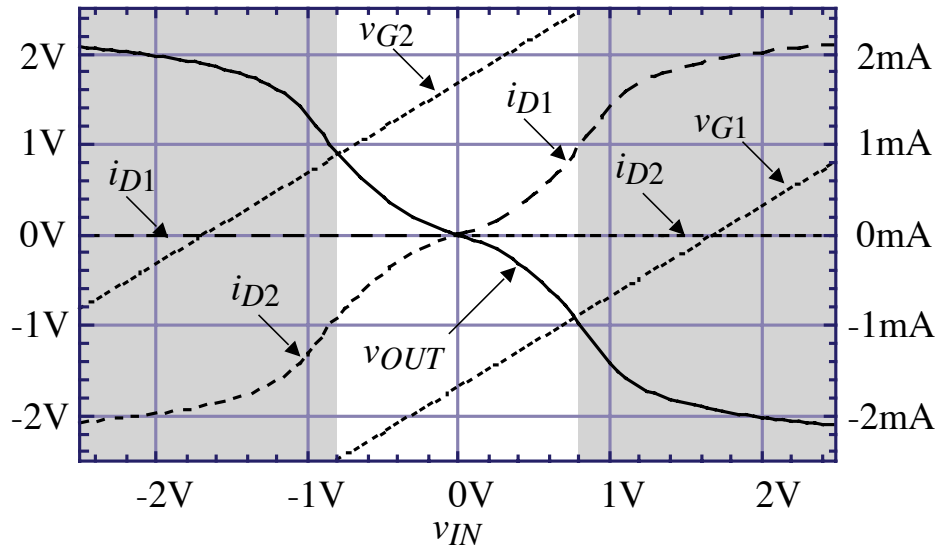

Class B, push-pull, inverting amplifier.

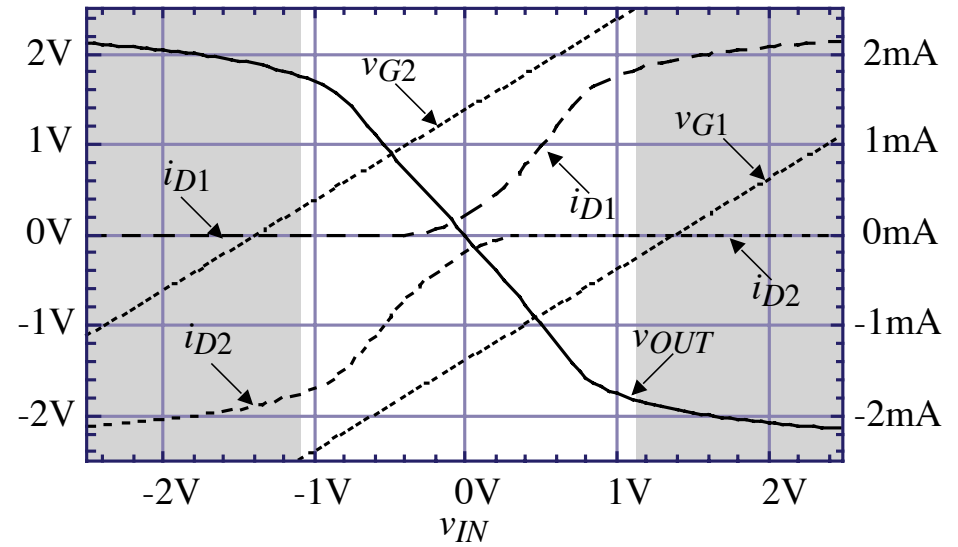

Class AB, push-pull, inverting amplifier. Fig.060-06

Comments:

- Note that there is significant distortion at $v_{IN} = 0V$ for the Class B inverter
- Note that v_{OUT} cannot reach the extreme values of V_{DD} and V_{SS}
- $I_{OUT}^+(\text{max})$ and $I_{OUT}^-(\text{max})$ is always less than V_{DD}/R_L or V_{SS}/R_L
- For $v_{OUT} = 0V$, there is quiescent current flowing in M1 and M2 for Class AB

Practical Implementation of the Push-Pull, Common Source Amplifier – Method 1

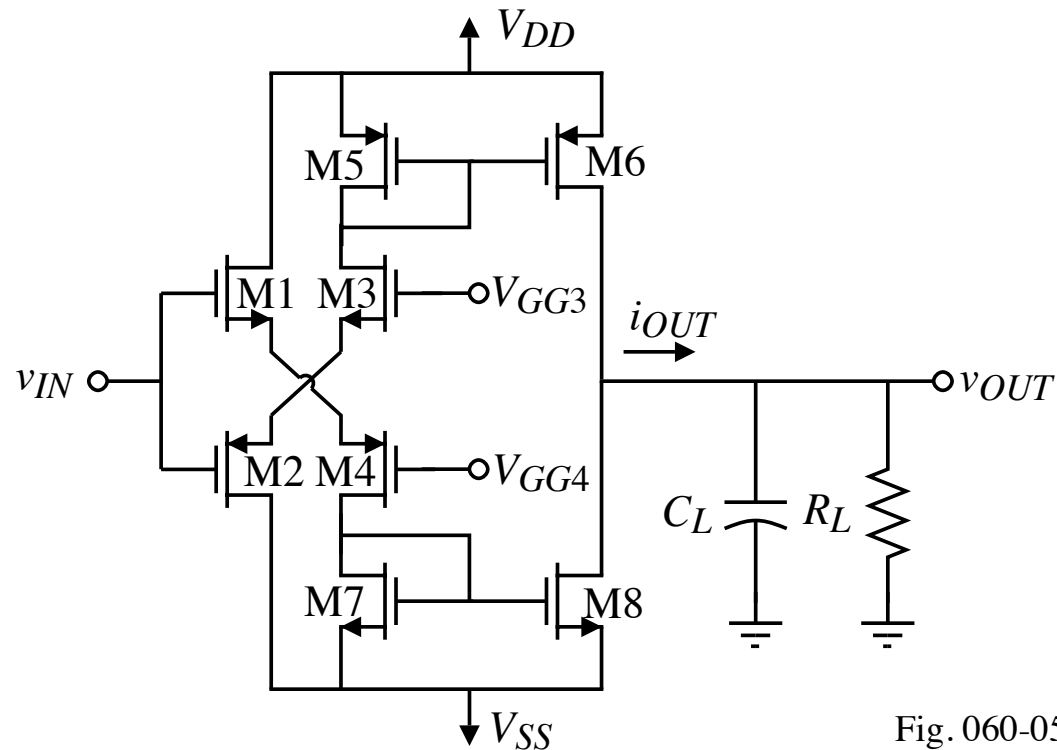

Fig. 060-05

V_{GG3} and V_{GG4} can be used to bias this amplifier in class AB or class B operation. Note, that the bias current in M6 and M8 is not dependent upon V_{DD} or V_{SS} (assuming V_{GG3} and V_{GG4} are not dependent on V_{DD} and V_{SS}).

Practical Implementation of the Push-Pull, Common Source Amplifier – Method 2

In steady-state, the current through M5 and M6 is $2I_b$. If $W_4/L_4 = W_9/L_9$ and $W_3/L_3 = W_8/L_8$, then the currents in M1 and M2 can be determined by the following relationship:

$$I_1 = I_2 = I_b \left(\frac{W_1/L_1}{W_7/L_7} \right) = I_b \left(\frac{W_2/L_2}{W_{10}/L_{10}} \right)$$

If v_{in}^+ goes low, M5 pulls the gates of M1 and M2 high. M4 shuts off causing all of the current flowing through M5 ($2I_b$) to flow through M3 shutting off M1. The gate of M2 is high allowing the buffer to strongly sink current. If v_{in}^- goes high, M6 pulls the gates of M1 and M2 low. As before, this shuts off M2 and turns on M1 allowing strong sourcing.

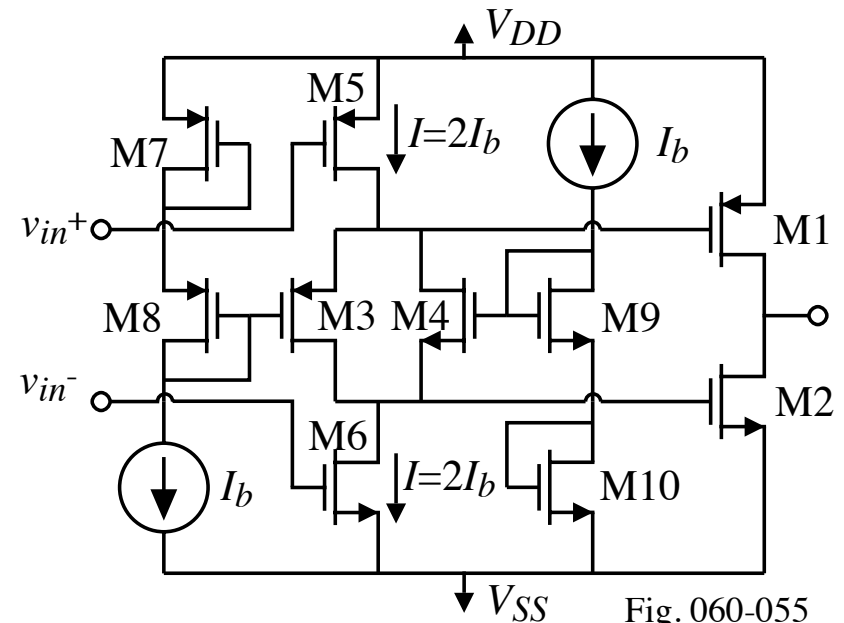

Additional Methods of Biasing the Push-Pull Common-Source Amplifier

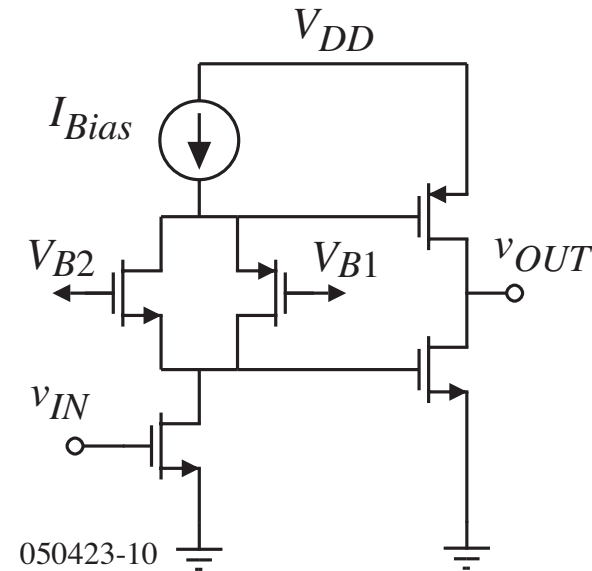
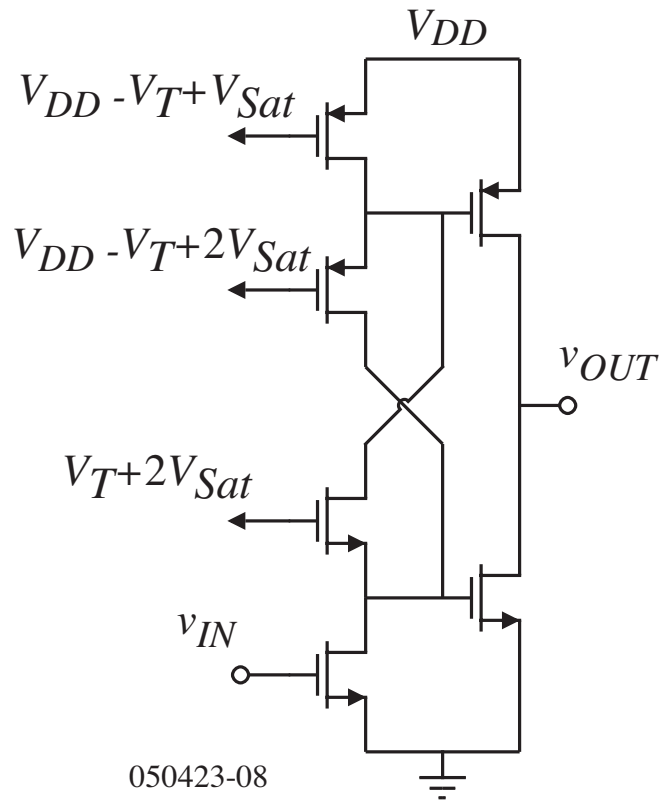

BIPOLAR JUNCTION TRANSISTOR OUTPUT AMPLIFIERS

What about the use of BJTs?

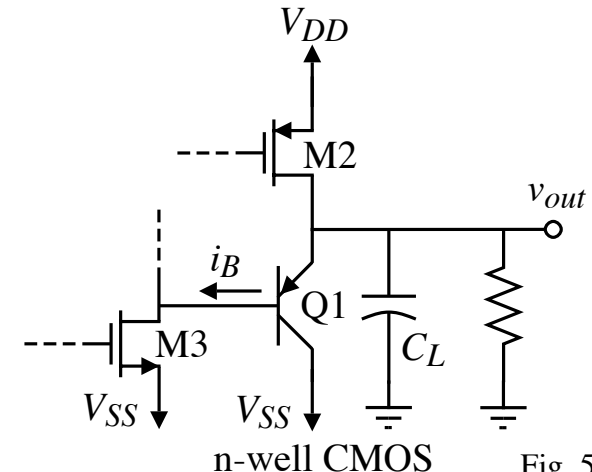
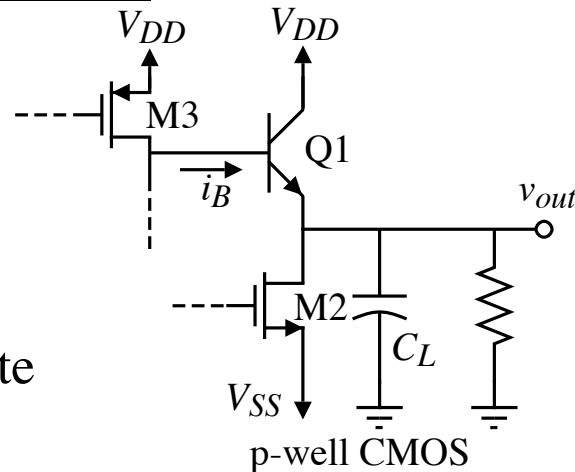

Fig. 5.5-8A

Comments:

- Can use either substrate or lateral BJTs.
- Small-signal output resistance is $1/g_m$ which can easily be less than 100Ω .
- Unfortunately, only PNP or NPN BJTs are available but not both on a standard CMOS technology.
- BJTs will cause substrate current unless they surrounded by a deep well
- In order for the BJT to sink (or source) large currents, the base current, i_B , must be large. Providing large currents as the voltage gets to extreme values is difficult for MOSFET circuits to accomplish.
- If one considers the MOSFET driver, the emitter can only pull to within $v_{BE} + V_{ON}$ of the power supply rails. This value can be 1V or more.

Low Output Resistance using BJTs

The output resistance of a class A BJT stage is:

$$R_{out} = \frac{r_{\pi 1} + R_B}{1 + \beta_F} = \frac{1}{g_{m1}} + \frac{R_B}{1 + \beta_F}$$

Note that the second term must be less than $1/g_{m1}$ in order to achieve the low output resistance possible.

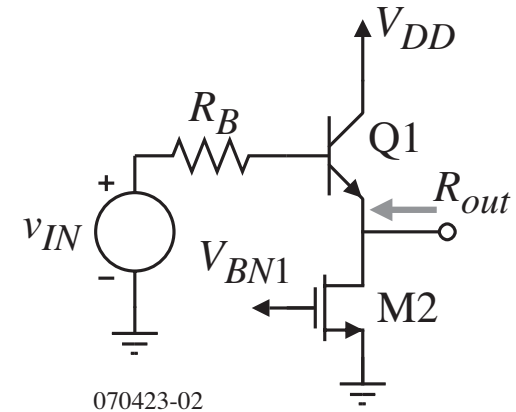

Consequently, the driver for the BJT should be a MOS follower as shown:

$$R_{out} = \frac{r_{\pi 1} + 1/g_{m3}}{1 + \beta_F} = \frac{1}{g_{m1}} + \frac{1}{g_{m3}(1 + \beta_F)} \approx \frac{1}{g_{m1}}$$

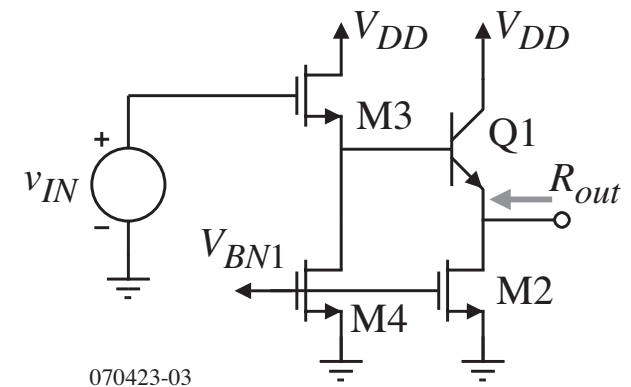

We will consider the BJT as an output stage in more detail later.

USING NEGATIVE FEEDBACK TO REDUCE THE OUTPUT RESISTANCE

Concept

Use negative shunt feedback – Class A implementation:

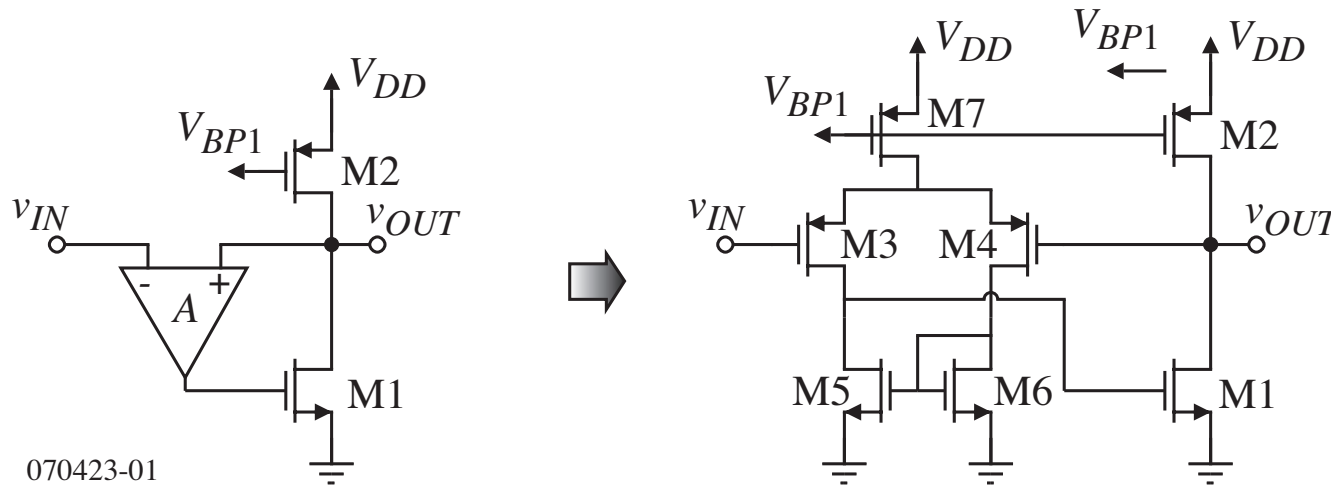

$$R_{out} = \frac{r_{ds1} \parallel r_{ds2}}{1 + \text{Loop Gain}} \approx \frac{1}{2g_m^2 r_{ds}} \approx 10\Omega \text{ if } g_m = 500\mu\text{S} \text{ and } g_m r_{ds} \approx 100.$$

The actual value of R_{out} will be influenced by the value of R_L , particularly if it is small.

Push-Pull Implementation

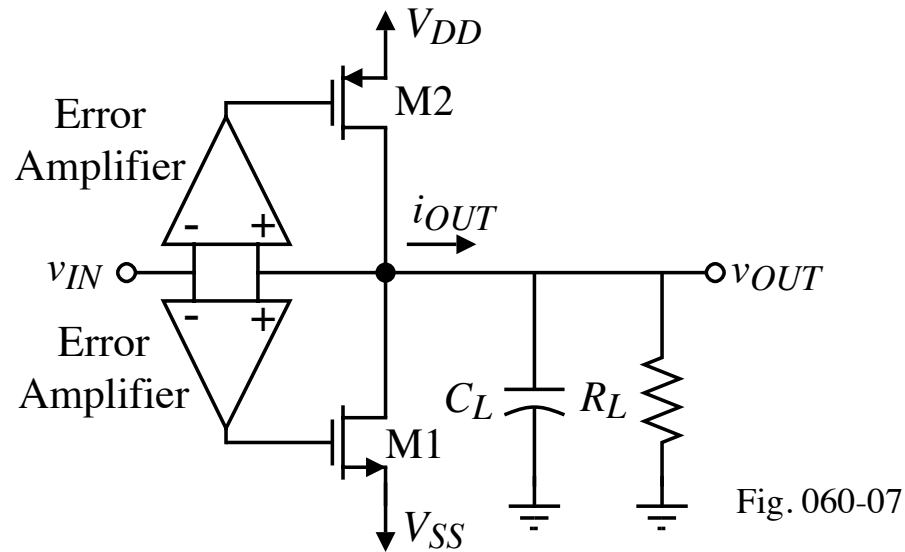

$$R_{out} = \frac{r_{ds1} \parallel r_{ds2}}{1 + \text{Loop Gain}}$$

Comments:

- Can achieve output resistances as low as 10Ω .
- If the error amplifiers are not balanced, it is difficult to control the quiescent current in M1 and M2
- Great linearity because of the strong feedback
- Can be efficient if operated in class B or class AB
- We will consider this circuit in more detail in a later lecture.

Boosting the Transconductance of the Source Follower

The following configuration allows the output resistance of the source follower to be decreased by a factor of K , where K is the current ratio between M4 and M3.

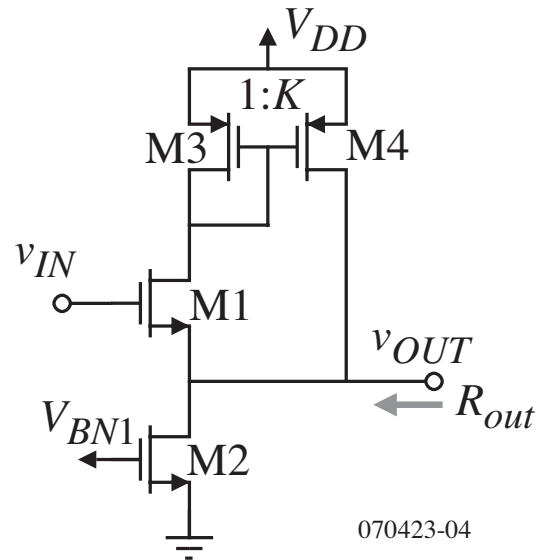

$$R_{out} = \frac{1}{g_{m1}K}$$

SUMMARY

- The objectives are to provide output power in form of voltage and/or current.
- In addition, the output amplifier should be linear and be efficient.
- Low output resistance is required to provide power efficiently to a small load resistance.
- High source/sink currents are required to provide sufficient output voltage rate due to large load capacitances.
- Types of output amplifiers considered:
 - Class A amplifier
 - Source follower
 - Class B and AB amplifier
 - Use of BJTs
 - Negative shunt feedback