

CHAPTER 8 – COMPARATORS

Chapter Outline

- 8.1 Characterization of Comparators
- 8.2 Two-Stage, Open-Loop Comparators
- 8.3 Other Open-Loop Comparators
- 8.4 Improving the Performance of Open-Loop Comparators
- 8.5 Discrete-Time Comparators
- 8.6 High-Speed Comparators
- 8.7 Summary

SECTION 8.1 – CHARACTERIZATION OF COMPARATORS

Objective

The objective of this section is:

- 1.) Introduction to the comparator
- 2.) Characterization of the comparator

Outline

- Static characterization
- Dynamic characterization
- Summary

What is a Comparator?

The comparator is essentially a 1-bit analog-digital converter.

Input is analog

Output is digital

Types of comparators:

- Open-loop (op amps without compensation)
- Regenerative (use of positive feedback - latches)
- Combination of open-loop and regenerative comparators

Circuit Symbol for a Comparator

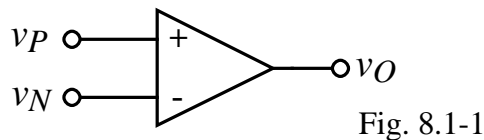

Static Characteristics

- Gain
- Output high and low states
- Input resolution
- Offset
- Noise

Dynamic Characteristics

- Propagation delay
- Slew rate

Noninverting and Inverting Comparators

The comparator output is binary with the two-level outputs defined as,

V_{OH} = the high output of the comparator

V_{OL} = the low level output of the comparator

Voltage transfer function of an Noninverting and Inverting Comparator:

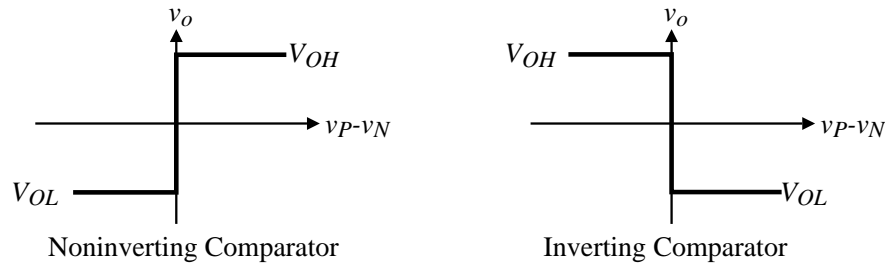

Fig. 8.1-2A

Static Characteristics - Zero-order Model for a Comparator

Voltage transfer function curve:

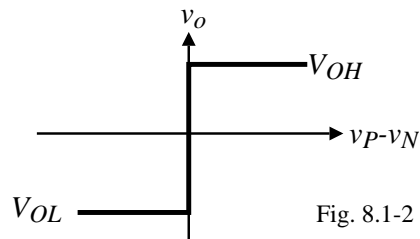

Fig. 8.1-2

Model:

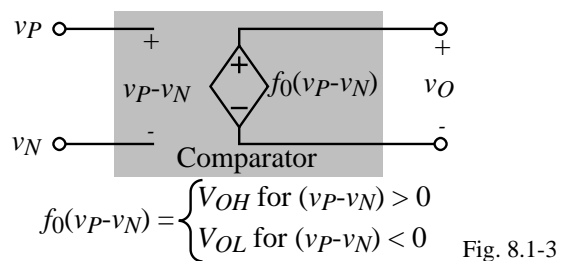

Fig. 8.1-3

$$\text{Gain} = A_v = \lim_{\Delta V \rightarrow 0} \frac{V_{OH} - V_{OL}}{\Delta V} \text{ where } \Delta V \text{ is the input voltage change}$$

Static Characteristics - First-Order Model for a Comparator

Voltage transfer curve:

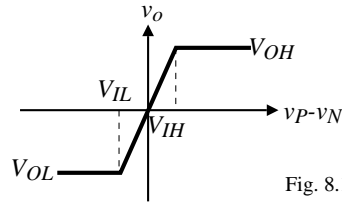

Fig. 8.1-4

where for a noninverting comparator,

V_{IH} = smallest input voltage at which the output voltage is V_{OH}

V_{IL} = largest input voltage at which the output voltage is V_{OL}

Model:

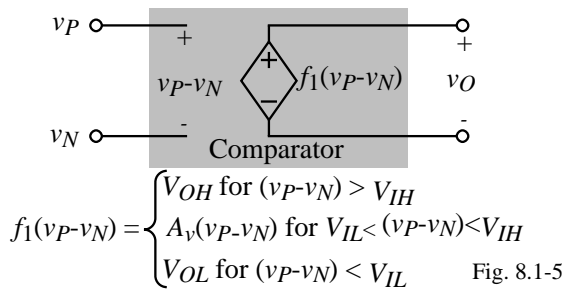

The voltage gain is $A_v = \frac{V_{OH} - V_{OL}}{V_{IH} - V_{IL}}$

Static Characteristics - First-Order Model including Input Offset Voltage

Voltage transfer curve:

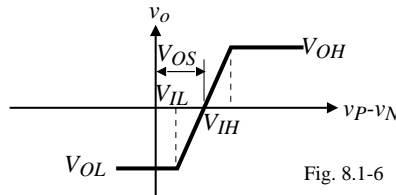

Fig. 8.1-6

V_{OS} = the input voltage necessary to make the output equal $\frac{V_{OH} + V_{OL}}{2}$ when $v_P = v_N$.

Model:

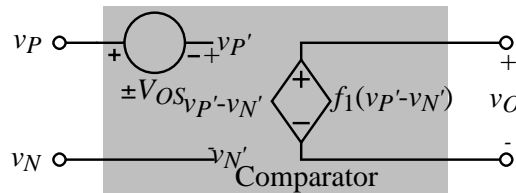

Fig. 8.1-7

Other aspects of the model:

$ICMR$ = input common mode voltage range (all transistors remain in saturation)

R_{in} = input differential resistance

R_{icm} = common mode input resistance

Static Characteristics - Comparator Noise

Noise of a comparator is modeled as if the comparator were biased in the transition region.

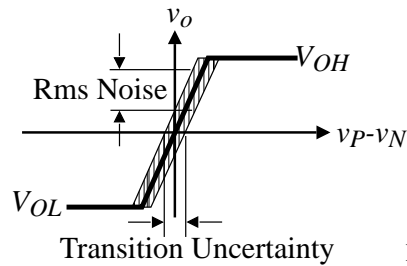

Fig. 8.1-8

Noise leads to an uncertainty in the transition region which causes jitter or phase noise.

Dynamic Characteristics - Propagation Time Delay

Rising propagation delay time:

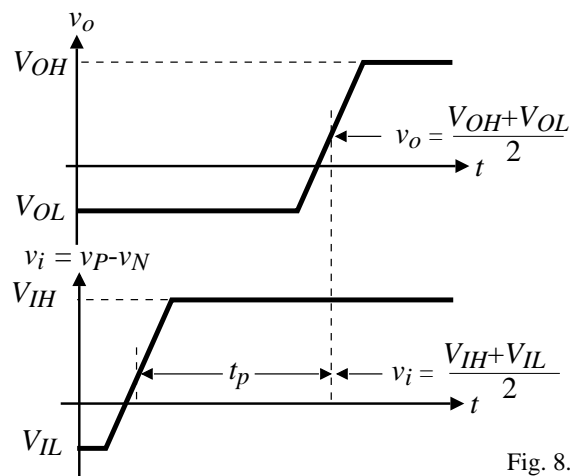

Fig. 8.1-9

Propagation delay time =

$$\frac{\text{Rising propagation delay time} + \text{Falling propagation delay time}}{2}$$

Dynamic Characteristics - Single-Pole Response

Model:

$$A_v(s) = \frac{A_v(0)}{s} = \frac{A_v(0)}{\frac{\omega_c}{s} + 1}$$

where

$A_v(0)$ = dc voltage gain of the comparator

$\omega_c = \frac{1}{\tau_c}$ = -3dB frequency of the comparator or the magnitude of the pole

Step Response:

$$v_o(t) = A_v(0) [1 - e^{-t/\tau_c}] V_{in}$$

where

V_{in} = the magnitude of the step input.

Dynamic Characteristics - Propagation Time Delay

The rising propagation time delay for a single-pole comparator is:

$$\frac{V_{OH} - V_{OL}}{2} = A_v(0) [1 - e^{-t_p/\tau_c}] V_{in} \quad \rightarrow \quad t_p = \tau_c \ln \left[\frac{1}{1 - \frac{V_{OH} - V_{OL}}{2A_v(0)V_{in}}} \right]$$

Define the minimum input voltage to the comparator as,

$$V_{in(\min)} = \frac{V_{OH} - V_{OL}}{A_v(0)} \quad \rightarrow \quad t_p = \tau_c \ln \left[\frac{1}{1 - \frac{V_{OH} - V_{OL}}{2V_{in}}} \right]$$

Define k as the ratio of the input step voltage, V_{in} , to the minimum input voltage,

$V_{in(\min)}$,

$$k = \frac{V_{in}}{V_{in(\min)}} \quad \rightarrow \quad t_p = \tau_c \ln \left[\frac{2k}{2k-1} \right]$$

Thus, if $k = 1$, $t_p = 0.693\tau_c$.

Illustration:

Obviously, the more overdrive applied to the input, the smaller the propagation delay time.

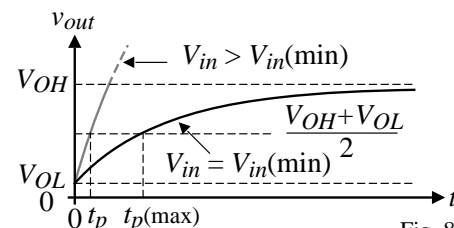
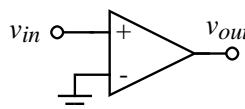

Dynamic Characteristics - Slew Rate of a Comparator

If the rate of rise or fall of a comparator becomes large, the dynamics may be limited by the slew rate.

Slew rate comes from the relationship,

$$i = C \frac{dv}{dt}$$

where i is the current through a capacitor and v is the voltage across it.

If the current becomes limited, then the voltage rate becomes limited.

Therefore for a comparator that is slew rate limited we have,

$$t_p = \Delta T = \frac{\Delta V}{SR} = \frac{V_{OH} - V_{OL}}{2 \cdot SR}$$

where

SR = slew rate of the comparator.

Example 8.1-1 - Propagation Delay Time of a Comparator

Find the propagation delay time of an open loop comparator that has a dominant pole at 10^3 radians/sec, a dc gain of 10^4 , a slew rate of $1V/\mu s$, and a binary output voltage swing of $1V$. Assume the applied input voltage is $10mV$.

Solution

The input resolution for this comparator is $1V/10^4$ or $0.1mV$. Therefore, the $10mV$ input is 100 times larger than $v_{in}(\min)$ giving a k of 100. Therefore, we get

$$t_p = \frac{1}{10^3} \ln\left(\frac{2 \cdot 100}{2 \cdot 100 - 1}\right) = 10^{-3} \ln\left(\frac{200}{199}\right) = 5.01\mu s$$

For slew rate considerations, we get

$$t_p = \frac{1}{2 \cdot 1 \times 10^6} = 0.5\mu s$$

Therefore, the propagation delay time for this case is the larger or $5.01\mu s$.

SECTION 8.2 – TWO-STAGE OPEN-LOOP COMPARATORS

Objective

The objective of this section is:

1.) Illustrate the performance and design of a two-stage open-loop comparator

Outline

- Two-stage, open-loop comparator performance
- Initial states of the two-stage, open-loop comparator
- Propagation delay time of a slewing, two-stage, open-loop comparator
- Design of a two-stage, open-loop comparator
- Summary

Two-Stage Comparator

An important category of comparators are those which use a high-gain stage to drive their outputs between V_{OH} and V_{OL} for very small input voltage changes.

The two-stage op amp without compensation is an excellent implementation of a high-gain, open-loop comparator.

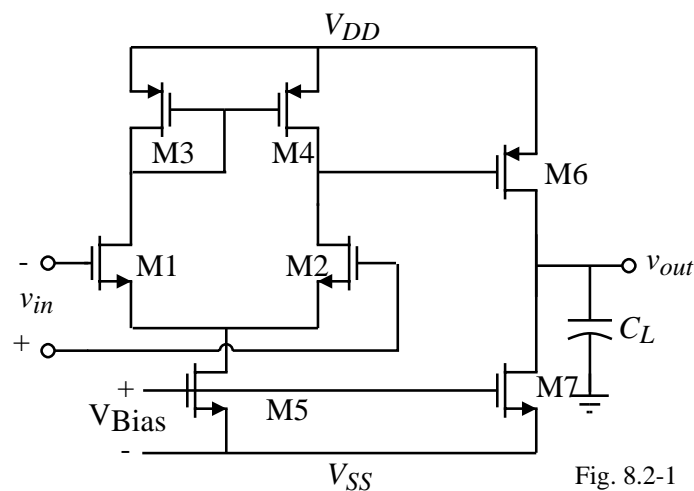

Fig. 8.2-1

Performance of the Two-Stage, Open-Loop Comparator

We know the performance should be similar to the uncompensated two-stage op amp.

Emphasis on comparator performance:

- Maximum output voltage

$$V_{OH} = V_{DD} - (V_{DD} - V_{G6(\min)} - |V_{TP}|) \left[1 - \sqrt{1 - \frac{8I_7}{\beta_6(V_{DD} - V_{G6(\min)} - |V_{TP}|)^2}} \right]$$

- Minimum output voltage

$$V_{OL} = V_{SS}$$

- Small-signal voltage gain

$$A_v(0) = \left(\frac{g_{m1}}{g_{ds2} + g_{ds4}} \right) \left(\frac{g_{m6}}{g_{ds6} + g_{ds7}} \right)$$

- Poles

Input:

$$p_1 = \frac{-(g_{ds2} + g_{ds4})}{C_I}$$

Output:

$$p_2 = \frac{-(g_{ds6} + g_{ds7})}{C_{II}}$$

- Frequency response

$$A_v(s) = \frac{A_v(0)}{\left(\frac{s}{p_1} - 1 \right) \left(\frac{s}{p_2} - 1 \right)}$$

Example 8.2-1 - Performance of a Two-Stage Comparator

Evaluate V_{OH} , V_{OL} , $A_v(0)$, $V_{in(\min)}$, p_1 , p_2 , for the two-stage comparator in Fig. 8.2-1. Assume that this comparator is the circuit of Ex. 6.3-1 with no compensation capacitor, C_c , and the minimum value of $V_{G6} = 0V$. Also, assume that $C_I = 0.2pF$ and $C_{II} = 5pF$.

Solution

Using the above relations, we find that

$$V_{OH} = 2.5 - (2.5 - 0 - 0.7) \left[1 - \sqrt{1 - \frac{8 \cdot 234 \times 10^{-6}}{50 \times 10^{-6} \cdot 38 (2.5 - 0 - 0.7)^2}} \right] = 2.2V$$

The value of V_{OL} is $-2.5V$. The gain was evaluated in Ex. 6.3-1 as $A_v(0) = 7696$. Therefore, the input resolution is

$$V_{in(\min)} = \frac{V_{OH} - V_{OL}}{A_v(0)} = \frac{4.7V}{7696} = 0.611mV$$

Next, we find the poles of the comparator, p_1 and p_2 . From Ex. 6.3-1 we find that

$$p_1 = - \frac{g_{ds2} + g_{ds4}}{C_I} = - \frac{15 \times 10^{-6} (0.04 + 0.05)}{0.2 \times 10^{-12}} = -6.75 \times 10^6 \text{ (1.074MHz)}$$

and

$$p_2 = - \frac{g_{ds6} + g_{ds7}}{C_{II}} = - \frac{95 \times 10^{-6} (0.04 + 0.05)}{5 \times 10^{-12}} = -1.71 \times 10^6 \text{ (0.272MHz)}$$

Linear Step Response of the Two-Stage Comparator

The step response of a circuit with two real poles ($p_1 \neq p_2$) is,

$$v_{out}(t) = A_v(0)V_{in} \left[1 + \frac{p_2 e^{tp_1}}{p_1 - p_2} - \frac{p_1 e^{tp_2}}{p_1 - p_2} \right]$$

Normalizing gives,

$$v_{out}'(t_n) = \frac{v_{out}(t)}{A_v(0)V_{in}} = 1 - \frac{m}{m-1}e^{-t_n} + \frac{1}{m-1}e^{-mt_n} \text{ where } m = \frac{p_2}{p_1} \neq 1 \text{ and } t_n = -tp_1$$

If $p_1 = p_2$ ($m=1$), then

$$v_{out}'(t_n) = 1 - e^{-t_n} + t_n e^{-t_n} = 1 - e^{-t_n} - t_n e^{-t_n}$$

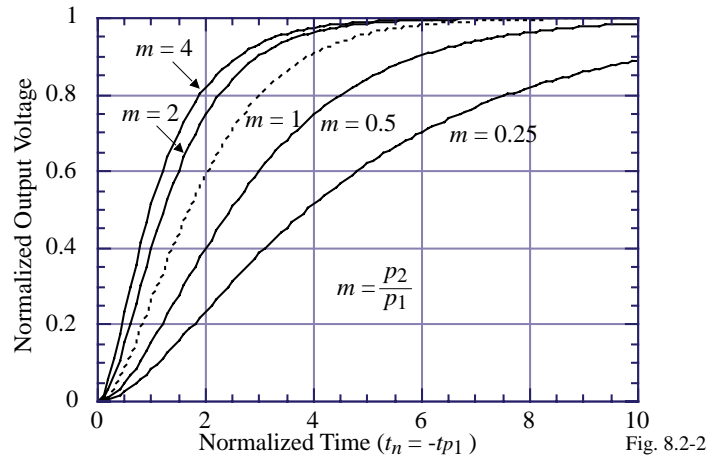

Fig. 8.2-2

Linear Step Response of the Two-Stage Comparator - Continued

The above results are valid as long as the slope of the linear response does not exceed the slew rate.

- Slope at $t = 0$ is zero
- Maximum slope occurs at ($m \neq 1$)

$$t_n(\text{max}) = \frac{\ln(m)}{m-1}$$

and is

$$\frac{dv_{out}'(t_n(\text{max}))}{dt_n} = \frac{m}{m-1} \left[\exp\left(\frac{-\ln(m)}{m-1}\right) - \exp\left(-m \frac{\ln(m)}{m-1}\right) \right]$$

- For the two-stage comparator using NMOS input transistors, the slew rate is

$$SR^- = \frac{I_7}{C_{II}}$$

$$SR^+ = \frac{I_6 - I_7}{C_{II}} = \frac{0.5\beta_6(V_{DD} - V_{G6(\text{min})} - |V_{TP}|)^2 - I_7}{C_{II}}$$

Example 8.2-2 - Step Response of Ex. 8.2-1

Find the maximum slope of Ex. 8.2-1 and the time it occurs if the magnitude of the input step is $v_{in}(\text{min})$. If the dc bias current in M7 is $100\mu\text{A}$, at what value of load capacitance, C_L would the transient response become slew limited? If the magnitude of the input step is $100v_{in}(\text{min})$, what is the new value of C_L at which slewing would occur?

Solution

The poles of the comparator were given in Ex. 8.2-1 as $p_1 = -6.75 \times 10^6$ rads/sec. and $p_2 = -1.71 \times 10^6$ rads/sec. This gives a value of $m = 0.253$. From the previous expressions, the maximum slope occurs at $t_n(\text{max}) = 1.84$ secs. Dividing by $|p_1|$ gives $t(\text{max}) = 0.272\mu\text{s}$. The slope of the transient response at this time is found as

$$\frac{dv_{out}'(t_n(\text{max}))}{dt_n} = -0.338[\exp(-1.84) - \exp(-0.253 \cdot 1.84)] = 0.159 \text{ V/sec}$$

Multiplying the above by $|p_1|$ gives $\frac{dv_{out}'(t(\text{max}))}{dt} = 1.072 \text{ V}/\mu\text{s}$

Therefore, if the slew rate is less than $1.072 \text{ V}/\mu\text{s}$, the transient response will experience slewing. Also, if $C_L \geq 100\mu\text{A}/1.072 \text{ V}/\mu\text{s}$ or 93.3 pF , the comparator will slew.

If the input is $100v_{in}(\text{min})$, then we must unnormalize the output slope as follows.

$$\frac{dv_{out}'(t(\text{max}))}{dt} = \frac{v_{in}}{v_{in}(\text{min})} \frac{dv_{out}'(t(\text{max}))}{dt} = 100 \cdot 1.072 \text{ V}/\mu\text{s} = 107.2 \text{ V}/\mu\text{s}$$

Therefore, the comparator will now slew with a load capacitance of 0.933 pF .

Propagation Delay Time (Non-Slew)

To find t_p , we want to set $0.5(V_{OH}-V_{OL})$ equal to $v_{out}(t_n)$. However, $v_{out}(t_n)$ given as

$$v_{out}(t_n) = A_v(0)V_{in} \left[1 - \frac{m}{m-1}e^{-t_n} + \frac{1}{m-1}e^{-mt_n} \right]$$

can't be easily solved so approximate the step response as a power series to get

$$v_{out}(t_n) \approx A_v(0)V_{in} \left[1 - \frac{m}{m-1} \left(1 - t_n + \frac{t_n^2}{2} + \dots \right) + \frac{1}{m-1} \left(1 - mt_n + \frac{m^2 t_n^2}{2} + \dots \right) \right] \approx \frac{mt_n^2 A_v(0)V_{in}}{2}$$

Therefore, set $v_{out}(t_n) = 0.5(V_{OH}-V_{OL})$

$$\frac{V_{OH}-V_{OL}}{2} \approx \frac{mt_{pn}^2 A_v(0)V_{in}}{2}$$

or

$$t_{pn} \approx \sqrt{\frac{V_{OH}-V_{OL}}{mA_v(0)V_{in}}} = \sqrt{\frac{V_{in}(\text{min})}{mV_{in}}} = \frac{1}{\sqrt{mk}}$$

This approximation is particularly good for large values of k .

Example 8.2-3 - Propagation Delay Time of a Two-Pole Comparator (Non-Slew)

Find the propagation delay of Ex. 8.2-1 if $V_{in} = 10\text{mV}$, 100mV and 1V .

Solution

From Ex. 8.2-1 we know that $V_{in}(\text{min}) = 0.611\text{mV}$ and $m = 0.253$. For $V_{in} = 10\text{mV}$, $k = 16.366$ which gives $t_{pn} \approx 0.491$. The propagation time delay is equal to $0.491/6.75 \times 10^6$ or 72.9ns . This corresponds well with Fig. 8.2-2 where the normalized propagation time delay is the time at which the amplitude is $1/2k$ or 0.031 which corresponds to t_{pn} of approximately 0.5. Similarly, for $V_{in} = 100\text{mV}$ and 1V we get a propagation time delay of 23ns and 7.3ns , respectively.

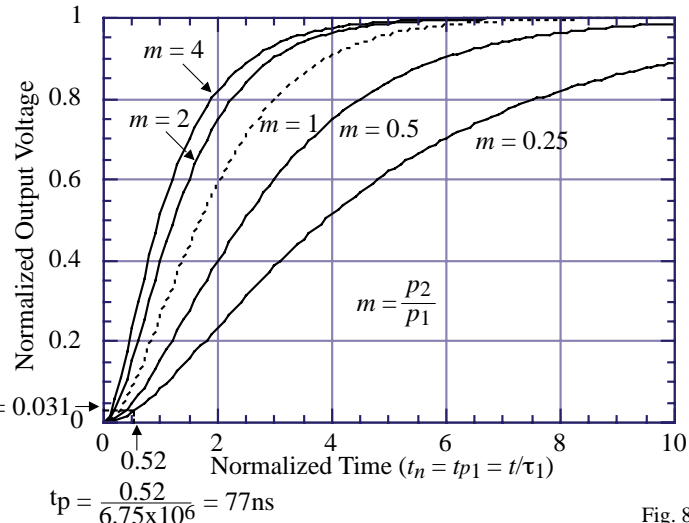

Fig. 8.2-2A

Initial Operating States for the Two-Stage, Open-Loop Comparator

What are the initial operating states for the two-stage, open-loop comparator?

1.) Assume $v_{G2} = V_{REF}$ and $v_{G1} > V_{REF}$ with $i_1 < I_{SS}$ and $i_2 > 0$.

Initially, $i_4 > i_2$ and v_{o1} increases, M4 becomes active and i_4 decreases until $i_3 = i_4$. v_{o1} is in the range of,

$V_{DD} - V_{SD4}(\text{sat}) < v_{o1} < V_{DD}$, $v_{G1} > V_{REF}$, $i_1 < I_{SS}$ and $i_2 > 0$
and the value of v_{out} is

$$v_{out} \approx V_{SS} \quad v_{G1} > V_{REF}, i_1 < I_{SS} \text{ and } i_2 > 0$$

2.) Assume $v_{G2} = V_{REF}$ and $v_{G1} \gg V_{REF}$, therefore $i_1 = I_{SS}$ and $i_2 = 0$ which gives

$$v_{o1} = V_{DD} \quad \text{and} \quad v_{out} = V_{SS}$$

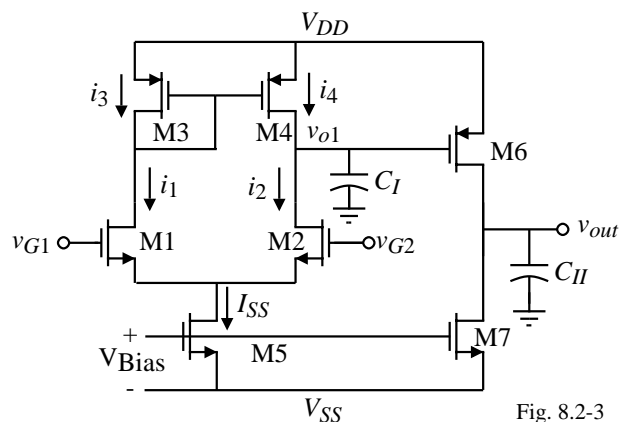

Fig. 8.2-3

Initial Operating States - Continued

3.) Assume $v_{G2} = V_{REF}$ and $v_{G1} < V_{REF}$ with $i_1 > 0$ and $i_2 < I_{SS}$.

Initially, $i_4 < i_2$ and v_{o1} decreases. When $v_{o1} \leq V_{REF} - V_{TN}$, M2 becomes active and i_2 decreases. When $i_1 = i_2 = I_{SS}/2$ the circuit stabilizes and v_{o1} is in the range of,

$$V_{REF} - V_{GS2} < v_{o1} < V_{REF} - V_{GS2} + V_{DS2}(\text{sat})$$

or

$$V_{S2} < v_{o1} < V_{S2} + V_{DS2}(\text{sat}), \quad v_{G1} < V_{G2}, i_1 > 0 \text{ and } i_2 < I_{SS}$$

For the above conditions,

$$v_{out} = V_{DD} - (V_{DD} - v_{o1} - |V_{TP}|) \left[1 - \sqrt{1 - \frac{\beta_7 I_{SS}}{\beta_5 \beta_6 (V_{DD} - v_{o1} - |V_{TP}|)^2}} \right]$$

4.) Assume $v_{G2} = V_{REF}$ and $v_{G1} \ll V_{REF}$, therefore $i_2 = I_{SS}$ and $i_1 = 0$.

Same as in 3.) but now as v_{o1} approaches v_{S2} with $I_{SS}/2$ flowing, the value of v_{GS2} becomes larger and M5 becomes active and I_{SS} decreases. In the limit, $I_{SS} \rightarrow 0, v_{DS2} \approx 0$ and $v_{DS5} \approx 0$ resulting in

$$v_{o1} \approx V_{SS} \quad \text{and} \quad v_{out} = V_{DD} - (V_{DD} - V_{SS} - |V_{TP}|) \left[1 - \sqrt{1 - \frac{\beta_7 I_{SS}}{\beta_5 \beta_6 (V_{DD} - V_{SS} - |V_{TP}|)^2}} \right]$$

Initial Operating States - Continued

5.) Assume $v_{G1} = V_{REF}$ and $v_{G2} > V_{REF}$ with $i_2 < I_{SS}$ and $i_1 > 0$.

Initially, $i_4 < i_2$ and v_{o1} falls, M2 becomes active and i_2 decreases until $i_1 = i_2 = I_{SS}/2$. Therefore,

$$V_{REF} - V_{GS2}(I_{SS}/2) < v_{o1} < V_{REF} - V_{GS2}(I_{SS}/2) + V_{DS2}(\text{sat})$$

or

$$V_{S2}(I_{SS}/2) < v_{o1} < V_{S2}(I_{SS}/2) + V_{DS2}(\text{sat}), \quad v_{G2} > V_{REF}, i_1 > 0 \text{ and } i_2 < I_{SS}$$

and the value of v_{out} is

$$v_{out} = V_{DD} - (V_{DD} - v_{o1} - |V_{TP}|) \left[1 - \sqrt{1 - \frac{\beta_7 I_{SS}}{\beta_5 \beta_6 (V_{DD} - v_{o1} - |V_{TP}|)^2}} \right]$$

6.) Assume that $v_{G1} = V_{REF}$ and $v_{G2} \gg V_{REF}$. When the source voltage of M1 or M2 causes M5 to be active, then I_{SS} decreases and

$$v_{o1} \approx V_{SS} \quad \text{and} \quad v_{out} = V_{DD} - (V_{DD} - V_{SS} - |V_{TP}|) \left[1 - \sqrt{1 - \frac{\beta_7 I_{SS}}{\beta_5 \beta_6 (V_{DD} - V_{SS} - |V_{TP}|)^2}} \right]$$

7.) Assume $v_{G1} = V_{REF}$ and $v_{G2} < V_{REF}$ and $i_1 < I_{SS}$ and $i_2 > 0$. Consequently, $i_4 > i_2$ which causes v_{o1} to increase. When M4 becomes active i_4 decreases until $i_2 = i_4$ at which v_{o1} stabilizes at (M6 will be off under these conditions and $v_{out} \approx V_{SS}$).

$$V_{DD} - V_{SD4}(\text{sat}) < v_{o1} < V_{DD}, \quad v_{G2} < V_{REF}, i_1 < I_{SS} \text{ and } i_2 > 0$$

Initial Operating States - Continued

8.) Finally if $v_{G2} \ll V_{REF}$, then $i_1 = I_{SS}$ and $i_2 = 0$ and

$$v_{o1} \approx V_{DD} \quad \text{and} \quad v_{out} \approx V_{SS}$$

Summary of the Initial Operating States of the Two-Stage, Open-Loop Comparator using a N-channel, Source-coupled Input Pair:

Conditions	Initial State of v_{o1}	Initial State of v_{out}
$v_{G1} > v_{G2}$, $i_1 < I_{SS}$ and $i_2 > 0$	$V_{DD} - V_{SD4}(\text{sat}) < v_{o1} < V_{DD}$	V_{SS}
$v_{G1} \gg v_{G2}$, $i_1 = I_{SS}$ and $i_2 = 0$	V_{DD}	V_{SS}
$v_{G1} < v_{G2}$, $i_1 > 0$ and $i_2 < I_{SS}$	$v_{o1} = v_{G2} - V_{GS2, \text{act}}(I_{SS}/2)$, $\approx V_{SS}$ if M5 act.	Eq. (19), Sec. 5.1 for PMOS
$v_{G1} \ll v_{G2}$, $i_1 > 0$ and $i_2 < I_{SS}$	V_{SS}	Eq. (19), Sec. 5.1 for PMOS
$v_{G2} > v_{G1}$, $i_1 > 0$ and $i_2 < I_{SS}$	$V_{SS} < v_{o1} < V_{SS} + V_{DS2}(\text{sat})$	Eq. (19), Sec. 5.1 for PMOS
$v_{G2} \gg v_{G1}$, $i_1 > 0$ and $i_2 < I_{SS}$	$v_{o1} = v_{G1} - V_{GS1}(I_{SS}/2)$, $\approx V_{SS}$ if M5 active	Eq. (19), Sec. 5.1 for PMOS
$v_{G2} < v_{G1}$, $i_1 < I_{SS}$ and $i_2 > 0$	$V_{DD} - V_{SD4}(\text{sat}) < v_{o1} < V_{DD}$	V_{SS}
$v_{G2} \ll v_{G1}$, $i_1 = I_{SS}$ and $i_2 = 0$	V_{DD}	V_{SS}

Trip Point of an Inverter

In order to determine the propagation delay time, it is necessary to know when the second stage of the two-stage comparator begins to “turn on”.

Second stage:

Trip point:

Assume that M6 and M7 are saturated. (We know that the steepest slope occurs for this condition.)

Equate i_6 to i_7 and solve for v_{in} which becomes the trip point.

$$\therefore v_{in} = V_{TRP} = V_{DD} - |V_{TP}| - \sqrt{\frac{K_N(W_7/L_7)}{K_P(W_6/L_6)}} (V_{Bias} - V_{SS} - V_{TN})$$

Example:

If $W_7/L_7 = W_6/L_6$, $V_{DD} = 2.5\text{V}$, $V_{SS} = -2.5\text{V}$, and $V_{Bias} = 0\text{V}$ the trip point for the circuit above is

$$V_{TRP} = 2.5 - 0.7 - \sqrt{110/50} (0 + 2.5 - 0.7) = -0.870\text{V}$$

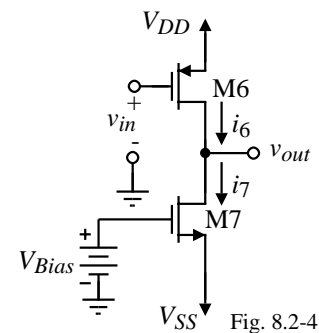

Propagation Delay Time of a Slewing, Two-Stage, Open-Loop Comparator

Previously we calculated the propagation delay time for a nonslewing comparator. If the comparator slews, then the propagation delay time is found from

$$i_i = C_i \frac{dv_i}{dt_i} = C_i \frac{\Delta v_i}{\Delta t_i}$$

where

C_i is the capacitance to ground at the output of the i -th stage

The propagation delay time of the i -th stage is,

$$t_i = \Delta t_i = C_i \frac{\Delta V_i}{I_i}$$

The propagation delay time is found by summing the delays of each stage.

$$t_p = t_1 + t_2 + t_3 + \dots$$

Example 8.2-5 - Propagation Time Delay of a Two-Stage, Open-Loop Comparator

For the two-stage comparator shown assume that $C_I = 0.2\text{pF}$ and $C_{II} = 5\text{pF}$. Also, assume that $v_{G1} = 0\text{V}$ and that v_{G2} has the waveform shown. If the input voltage is large enough to cause slew to dominate, find the propagation time delay of the rising and falling output of the comparator and give the propagation time delay of the comparator.

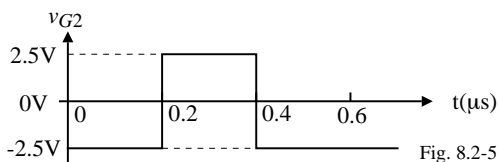

Fig. 8.2-5

Solution

- 1.) Total delay = sum of the first and second stage delays, t_1 and t_2
- 2.) First, consider the change of v_{G2} from -2.5V to 2.5V at $0.2\ \mu\text{s}$.

The last row of Table 8.2-1 gives $v_{o1} = +2.5\text{V}$ and $v_{out} = -2.5\text{V}$

- 3.) t_{f1} , requires C_I , ΔV_{o1} , and I_5 . $C_I = 0.2\text{pF}$, $I_5 = 30\ \mu\text{A}$ and ΔV_1 can be calculated by finding the trip point of the output stage/

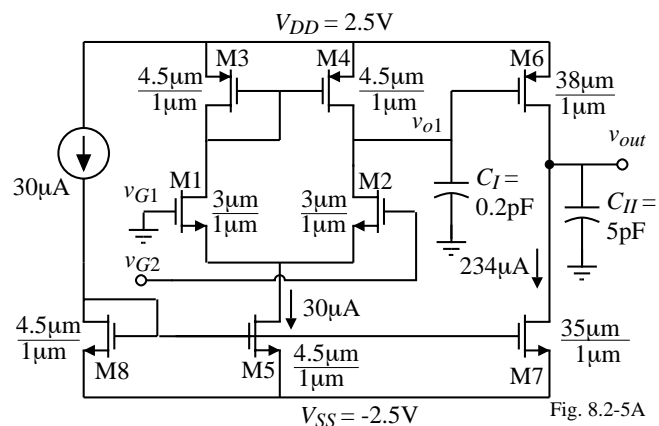

Fig. 8.2-5A

Example 8.2-5 - Continued

4.) The trip point of the output stage by setting the current of M6 when saturated equal to $234\mu\text{A}$.

$$\frac{\beta_6}{2} (V_{SG6} - |V_{TP}|)^2 = 234\mu\text{A} \rightarrow V_{SG6} = 0.7 + \sqrt{\frac{234 \cdot 2}{50 \cdot 38}} = 1.196\text{V}$$

Therefore, the trip point of the second stage is $V_{TRP2} = 2.5 - 1.196 = 1.304\text{V}$

Therefore, $\Delta V_1 = 2.5\text{V} - 1.304\text{V} = V_{SG6} = 1.196\text{V}$. Thus the falling propagation time delay of the first stage is

$$t_{fo1} = 0.2\text{pF} \left(\frac{1.196\text{V}}{30\mu\text{A}} \right) = 8\text{ ns}$$

5.) The rising propagation time delay of the second stage requires C_{II} , ΔV_{out} , and I_6 . C_{II} is given as 5pF , $\Delta V_{out} = 2.5\text{V}$ (assuming the trip point of the circuit connected to the output of the comparator is 0V), and I_6 can be found as follows:

$$V_{G6}(\text{guess}) \approx 0.5[V_{G6}(I_6=234\mu\text{A}) + V_{G6}(\text{min})]$$

$$V_{G6}(\text{min}) = V_{G1} - V_{GS1}(I_{SS}/2) + V_{DS2} \approx -V_{GS1}(I_{SS}/2) = -0.7 - \sqrt{\frac{2 \cdot 15}{110 \cdot 3}} = -1.00\text{V}$$

$$V_{G6}(\text{guess}) \approx 0.5(1.304\text{V} - 1.00\text{V}) = 0.152\text{V}$$

Therefore $V_{SG6} = 2.348\text{V}$ and $I_6 = \frac{\beta_6}{2} (V_{SG6} - |V_{TP}|)^2 = \frac{38 \cdot 50}{2} (2.348 - 0.7)^2 = 2,580\mu\text{A}$

Example 8.2-5 - Continued

6.) The rising propagation time delay for the output can be expressed as

$$t_{rout} = 5\text{pF} \left(\frac{2.5\text{V}}{2,580\mu\text{A} - 234\mu\text{A}} \right) = 5.3\text{ ns}$$

Thus the total propagation time delay of the rising output of the comparator is approximately 13.3 ns and most of this delay is attributable to the first stage.

7.) Next consider the change of v_{G2} from 2.5V to -2.5V which occurs at $0.4\mu\text{s}$. We shall assume that v_{G2} has been at 2.5V long enough for the conditions of Table 8.2-1 to be valid.

Therefore, $v_{o1} \approx V_{SS} = -2.5\text{V}$ and

$v_{out} \approx V_{DD}$. The propagation time delays for the first and second stages are calculated as

$$t_{ro1} = 0.2\text{pF} \left(\frac{1.304\text{V} - (-1.00\text{V})}{30\mu\text{A}} \right) = 15.4\text{ ns}$$

$$t_{fout} = 5\text{pF} \left(\frac{2.5\text{V}}{234\mu\text{A}} \right) = 53.42\text{ ns}$$

8.) The total propagation time delay of the falling output is 68.82 ns . Taking the average of the rising and falling propagation time delays gives a propagation time delay for this two-stage, open-loop comparator of about 41.06 ns .

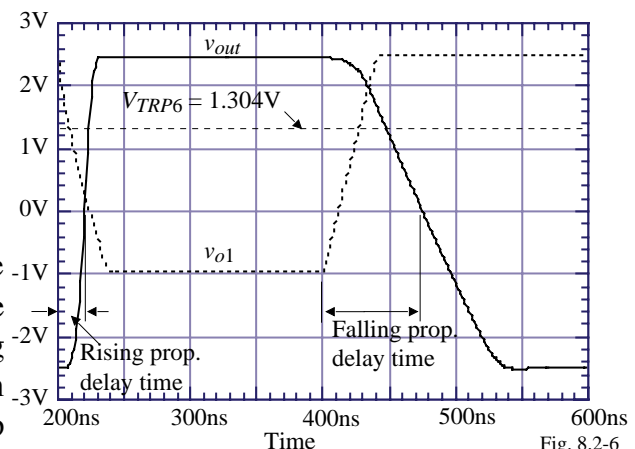

Fig. 8.2-6

Design of a Two-Stage, Open-Loop Comparator

Table 8.2-2 Design of the Two-Stage, Open-Loop Comparator of Fig. 8.2-3 for a Linear Response.

Step	Design Relationships	Comments
1	$ p_I = p_{II} = \frac{1}{t_p \sqrt{mk}}$, and $I_7 = I_6 = \frac{ p_{II} C_{II}}{\lambda_N + \lambda_P}$	Choose $m = 1$
2	$\frac{W_6}{L_6} = \frac{2 \cdot I_6}{K_P (V_{SD6}(\text{sat}))^2}$ and $\frac{W_7}{L_7} = \frac{2 \cdot I_7}{K_N (V_{DS7}(\text{sat}))^2}$	$V_{SD6}(\text{sat}) = V_{DD} - V_{OH}$ $V_{DS7}(\text{sat}) = V_{OL} - V_{SS}$
3	Guess C_I as 0.1pF to 0.5pF $\therefore I_5 = I_7 \frac{2C_I}{C_{II}}$	A result of choosing $m = 1$. Will check C_I later
4	$\frac{W_3}{L_3} = \frac{W_4}{L_4} = \frac{I_5}{K_P (V_{SG3} - V_{TP})^2}$	$V_{SG3} = V_{DD} - V_{icm}^+ + V_{TN}$
5	$g_{m1} = \frac{A_v(0)(g_{ds2} + g_{ds4})(g_{ds6} + g_{ds7})}{g_{m6}}$ $\frac{W_1}{L_1} = \frac{W_2}{L_2} = \frac{g_{m1}^2}{K_N I_5}$	$g_{m6} = \sqrt{\frac{2K_P W_6 I_6}{L_6}}$ $A_v(0) = \frac{V_{OH} - V_{OL}}{V_{in}(\text{min})}$
6	Find C_I and check assumption $C_I = C_{gd2} + C_{gd4} + C_{gs6} + C_{bd2} + C_{bd4}$	If C_I is greater than the guess in step 3, then increase C_I and repeat steps 4 through 6
7	$V_{DS5}(\text{sat}) = V_{icm}^- - V_{GS1} - V_{SS}$ $\frac{W_5}{L_5} = \frac{2 \cdot I_5}{K_N (V_{DS5}(\text{sat}))^2}$	If $V_{DS5}(\text{sat})$ is less than 100mV, increase W_1/L_1 .

Example 8.2-6 - Two-Stage, Open-Loop Comparator Design for a Linear Response.

Assume the specifications of the comparator shown are given below.

$$t_p = 50\text{ns} \quad V_{OH} = 2\text{V} \quad V_{OL} = -2\text{V}$$

$$V_{DD} = 2.5\text{V} \quad V_{SS} = -2.5\text{V} \quad C_{II} = 5\text{pF}$$

$$V_{in}(\text{min}) = 1\text{mV} \quad V_{icm}^+ = 2\text{V} \quad V_{icm}^- = -1.25\text{V}$$

Also assume that the overdrive will be a factor of 10. Use this architecture to achieve the above specifications and assume that all channel lengths are to be $1\mu\text{m}$.

Solution

Following the procedure outlined in Table 8.2-2, we choose $m = 1$ to get

$$|p_I| = |p_{II}| = \frac{10^9}{50\sqrt{10}} = 6.32 \times 10^6 \text{ rads/sec}$$

This gives

$$I_6 = I_7 = \frac{6.32 \times 10^6 \cdot 5 \times 10^{-12}}{0.04 + 0.05} = 351 \mu\text{A} \rightarrow I_6 = I_7 = 400 \mu\text{A}$$

Therefore,

$$\frac{W_6}{L_6} = \frac{2 \cdot 400}{(0.5)^2 \cdot 50} = 64 \quad \text{and} \quad \frac{W_7}{L_7} = \frac{2 \cdot 400}{(0.5)^2 \cdot 110} = 29$$

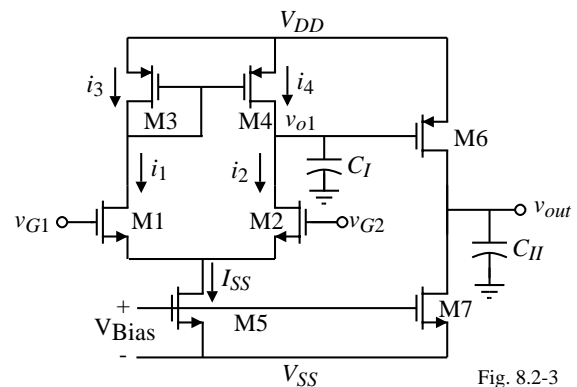

Fig. 8.2-3

Example 8.2-6 - Continued

Next, we guess $C_I = 0.2\text{pF}$. This gives $I_5 = 32\mu\text{A}$ and we will increase it to $40\mu\text{A}$ for a margin of safety. Step 4 gives V_{SG3} as 1.2V which results in

$$\frac{W_3}{L_3} = \frac{W_4}{L_4} = \frac{40}{50(1.2-0.7)^2} = 3.2 \quad \rightarrow \quad \frac{W_3}{L_3} = \frac{W_4}{L_4} = 4$$

The desired gain is found to be 4000 which gives an input transconductance of

$$g_{m1} = \frac{4000 \cdot 0.09 \cdot 20}{44.44} = 162\mu\text{S}$$

This gives the W/L ratios of M1 and M2 as

$$\frac{W_1}{L_1} = \frac{W_2}{L_2} = \frac{(162)^2}{110 \cdot 40} = 5.96 \quad \rightarrow \quad \frac{W_1}{L_1} = \frac{W_2}{L_2} = 6$$

To check the guess for C_I we need to calculate it which is done as

$$C_I = C_{gd2} + C_{gd4} + C_{gs6} + C_{bd2} + C_{bd4} = 0.9\text{fF} + 1.3\text{fF} + 119.5\text{fF} + 20.4\text{fF} + 36.8\text{fF} = 178.9\text{fF}$$

which is less than what was guessed so we will make no changes.

Example 8.2-6 - Continued

Finally, the W/L value of M5 is found by finding V_{GS1} as 0.946V which gives $V_{DS5}(\text{sat}) = 0.304\text{V}$. This gives

$$\frac{W_5}{L_5} = \frac{2 \cdot 40}{(0.304)^2 \cdot 110} = 7.87 \approx 8$$

Obviously, M5 and M7 cannot be connected gate-gate and source-source. The value of I_5 and I_7 must be derived separately as illustrated below. The W values are summarized below assuming that all channel lengths are $1\mu\text{m}$.

$$W_1 = W_2 = 6\mu\text{m} \quad W_3 = W_4 = 4\mu\text{m} \quad W_5 = 8\mu\text{m} \quad W_6 = 64\mu\text{m} \quad W_7 = 29\mu\text{m}$$

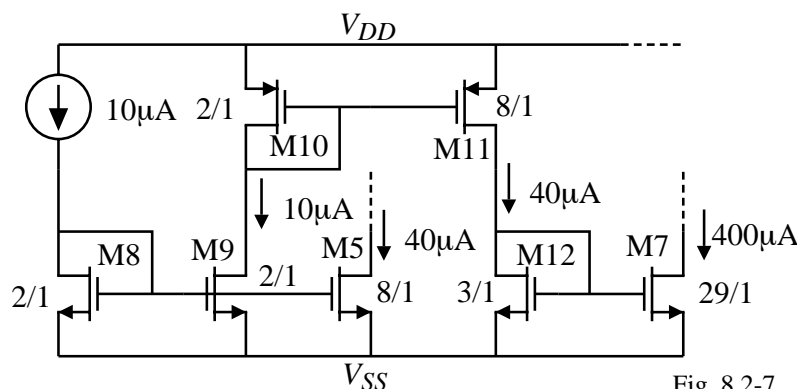

Fig. 8.2-7

Design of a Two-Stage Comparator for a Slewing Response

Table 8.2-3 Two-Stage, Open-Loop Comparator Design for a Slewing Response.

Step	Design Relationships	Comments
1	$I_7 = I_6 = C_{II} \frac{dv_{out}}{dt} = \frac{C_{II}(V_{OH}-V_{OL})}{t_p}$	Assume the trip point of the output is $(V_{OH}-V_{OL})/2$. Let $t_{p1} = t_{p2} = 0.5t_p$
2	$\frac{W_6}{L_6} = \frac{2 \cdot I_6}{K_P'(V_{SD6}(\text{sat}))^2}$ and $\frac{W_7}{L_7} = \frac{2 \cdot I_7}{K_N'(V_{DS7}(\text{sat}))^2}$	$V_{SD6}(\text{sat}) = V_{DD} - V_{OH}$ $V_{DS7}(\text{sat}) = V_{OL} - V_{SS}$
3	Guess C_I as 0.1pF to 0.5pF	Typically $0.1\text{pf} < C_I < 0.5\text{pF}$
4	$I_5 = C_I \frac{dv_{o1}}{dt} \approx \frac{C_I(V_{OH}-V_{OL})}{t_p}$	Assume that v_{o1} swings between V_{OH} and V_{OL} .
5	$\frac{W_3}{L_3} = \frac{W_4}{L_4} = \frac{I_5}{K_P'(V_{SG3}- V_{TP})^2}$	$V_{SG3} = V_{DD} - V_{icm}^+ + V_{TN}$
6	$g_{m1} = \frac{A_v(0)(g_{ds2}+g_{ds4})(g_{ds6}+g_{ds7})}{g_{m6}} \frac{W_1}{L_1} = \frac{W_2}{L_2} = \frac{g_{m1}^2}{K_N I_5}$	$g_{m6} = \sqrt{\frac{2K_P'W_6I_6}{L_6}}$ $A_v(0) = \frac{V_{OH}-V_{OL}}{V_{in}(\text{min})}$
7	Find C_I and check assumption $C_I = C_{gd2} + C_{gd4} + C_{gs6} + C_{bd2} + C_{bd4}$	If C_I is greater than the guess in step 3, increase the value of C_I and repeat steps 4 through 6
8	$V_{DS5}(\text{sat}) = V_{icm}^- - V_{GS1} - V_{SS} \frac{W_5}{L_5} = \frac{2 \cdot I_5}{K_N'(V_{DS5}(\text{sat}))^2}$	If $V_{DS5}(\text{sat})$ is less than 100mV, increase W_1/L_1 .

Example 8.2-7 - Two-Stage, Open-Loop Comparator Design for a Slewing Response

Assume the specifications of Fig. 8.2-3 are given below.

$$t_p = 50\text{ns} \quad V_{OH} = 2\text{V} \quad V_{OL} = -2\text{V} \quad V_{DD} = 2.5\text{V} \quad V_{SS} = -2.5\text{V}$$

$$C_{II} = 5\text{pF} \quad V_{in}(\text{min}) = 1\text{mV} \quad V_{icm}^+ = 2\text{V} \quad V_{icm}^- = -1.25\text{V}$$

Design a two-stage, open-loop comparator using the circuit of Fig. 8.2-3 to the above specifications and assume all channel lengths are to be $1\mu\text{m}$.

Solution

Following the procedure outlined in Table 8.2-3, we calculate I_6 and I_7 as

$$I_6 = I_7 = \frac{5 \times 10^{-12} \cdot 4}{50 \times 10^{-9}} = 400\mu\text{A}$$

Therefore,

$$\frac{W_6}{L_6} = \frac{2 \cdot 400}{(0.5)^2 \cdot 50} = 64 \quad \text{and} \quad \frac{W_7}{L_7} = \frac{2 \cdot 400}{(0.5)^2 \cdot 110} = 29$$

Next, we guess $C_I = 0.2\text{pF}$. This gives

$$I_5 = \frac{0.2\text{pF}(4\text{V})}{50\text{ns}} = 16\mu\text{A} \quad \rightarrow \quad I_5 = 20\mu\text{A}$$

Step 5 gives V_{SG3} as 1.2V which results in

$$\frac{W_3}{L_3} = \frac{W_4}{L_4} = \frac{20}{50(1.2-0.7)^2} = 1.6 \quad \rightarrow \quad \frac{W_3}{L_3} = \frac{W_4}{L_4} = 2$$

Example 8.2-7 - Continued

The desired gain is found to be 4000 which gives an input transconductance of

$$g_{m1} = \frac{4000 \cdot 0.09 \cdot 10}{44.44} = 81 \mu\text{S}$$

This gives the W/L ratios of M1 and M2 as

$$\frac{W_3}{L_3} = \frac{W_4}{L_4} = \frac{(81)^2}{110 \cdot 40} = 1.49 \quad \rightarrow \quad \frac{W_1}{L_1} = \frac{W_2}{L_2} = 2$$

To check the guess for C_I we need to calculate it which done as

$C_I = C_{gd2} + C_{gd4} + C_{gs6} + C_{bd2} + C_{bd4} = 0.9\text{fF} + 0.4\text{fF} + 119.5\text{fF} + 20.4\text{fF} + 15.3\text{fF} = 156.5\text{fF}$
which is less than what was guessed.

Finally, the W/L value of M5 is found by finding V_{GS1} as 1.00V which gives $V_{DS5}(\text{sat}) = 0.25\text{V}$. This gives

$$\frac{W_5}{L_5} = \frac{2 \cdot 20}{(0.25)^2 \cdot 110} = 5.8 \approx 6$$

As in the previous example, M5 and M7 cannot be connected gate-gate and source-source and a scheme like that of Example 8.2-6 must be used. The W values are summarized below assuming that all channel lengths are $1 \mu\text{m}$.

$$W_1 = W_2 = 2 \mu\text{m} \quad W_3 = W_4 = 4 \mu\text{m} \quad W_5 = 6 \mu\text{m} \quad W_6 = 64 \mu\text{m} \quad W_7 = 29 \mu\text{m}$$

SUMMARY

- The two-stage, open-loop comparator has two poles which should as large as possible
- The transient response of a two-stage, open-loop comparator will be limited by either the bandwidth or the slew rate
- It is important to know the initial states of a two-stage, open-loop comparator when finding the propagation delay time
- If the comparator is gainbandwidth limited then the poles should be as large as possible for minimum propagation delay time
- If the comparator is slew rate limited, then the current sinking and sourcing ability should be as large as possible

SECTION 8.3– OTHER OPEN-LOOP COMPARATORS

Objective

The objective of this section is:

1.) Show other types of continuous-time, open-loop comparators

Outline

- Push-pull comparators
- Comparators that can drive large capacitors

Push-Pull Comparators

Clamped:

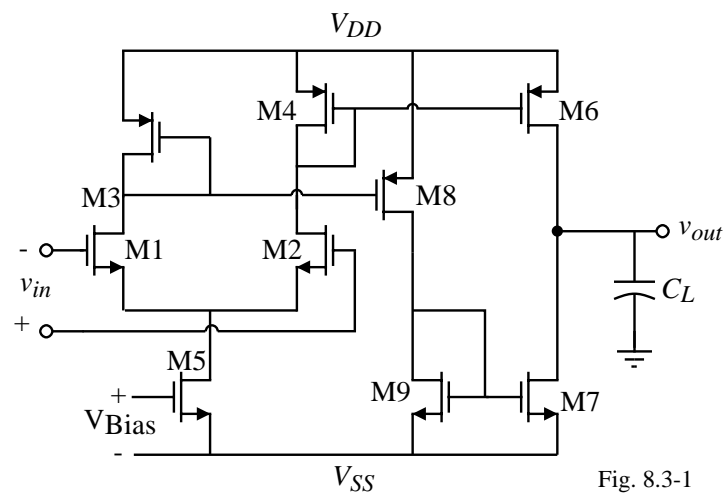

Fig. 8.3-1

Comments:

- Gain reduced → Larger input resolution
- Push-pull output → Higher slew rates

Push-Pull Comparators - Improved

Cascode output stage:

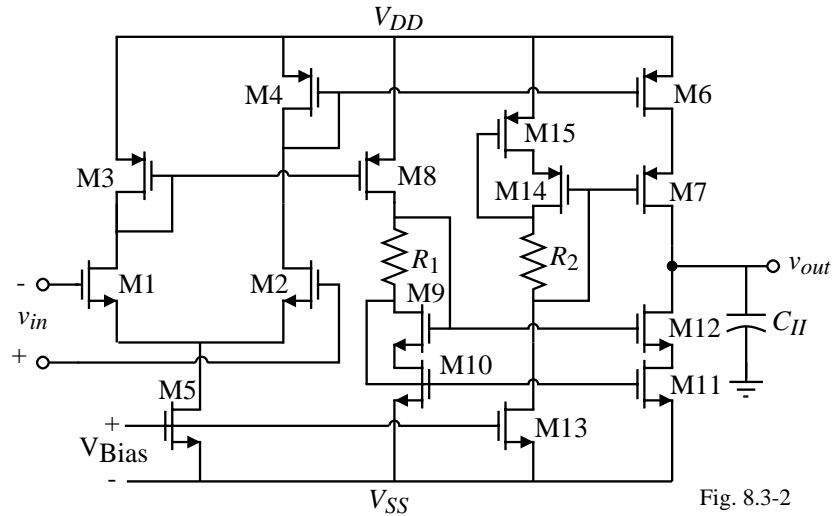

Fig. 8.3-2

Comments:

- Can also use the folded cascode architecture
- Cascode output stage result in a slow linear response (dominant pole is small)
- Poorer noise performance

Comparators that Can Drive Large Capacitive Loads

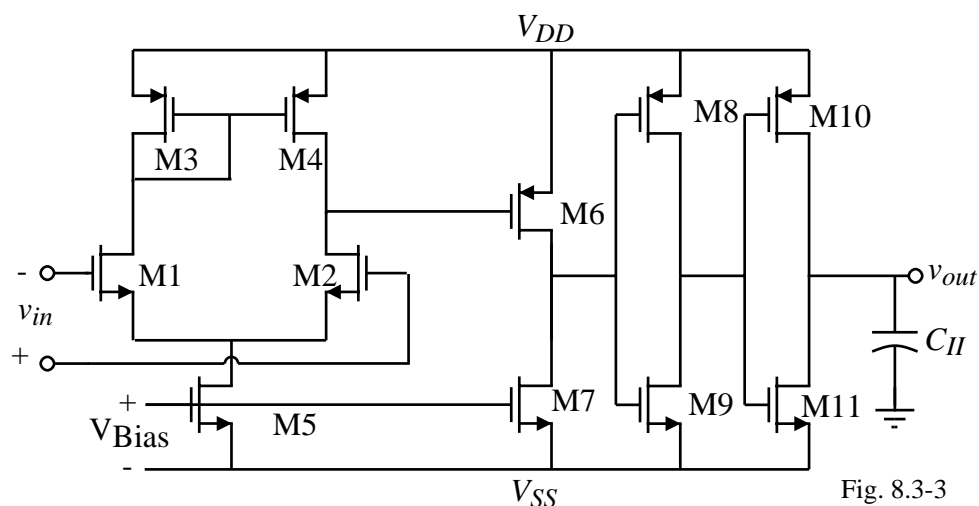

Fig. 8.3-3

Comments:

- Slew rate = $3\text{V}/\mu\text{s}$ into 50pF
- Linear rise/fall time = 100ns into 50pF
- Propagation delay time $\approx 1\mu\text{s}$
- Loop gain $\approx 32,000$ V/V

Self-Biased Differential Amplifier[†]

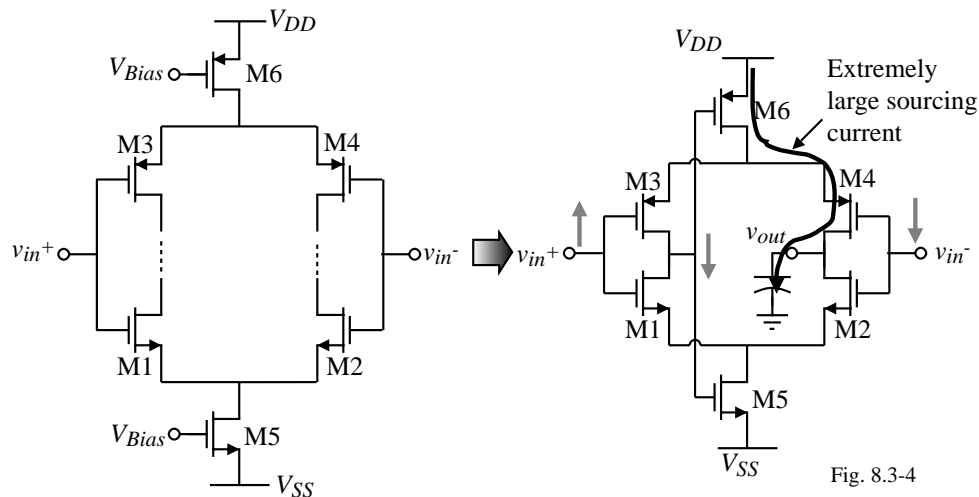

Fig. 8.3-4

Advantage:

Large sink or source current with out a large quiescent current.

Disadvantage:

Poor common mode range (v_{in}^+ slower than v_{in}^-)

[†] M. Bazes, "Two Novel Full Complementary Self-Biased CMOS Differential Amplifiers," *IEEE Journal of Solid-State Circuits*, Vol. 26, No. 2, Feb. 1991, pp. 165-168.

SECTION 8.4– IMPROVING THE PERFORMANCE OF COMPARATORS

Objective

The objective of this section is:

- 1.) Improve the performance of continuous-time, open-loop comparators

Outline

- Autozeroing techniques
- Comparators using hysteresis
- Summary

Autozeroing Techniques

Use the comparator as an op amp to sample the dc input offset voltage and cancel the offset during operation.

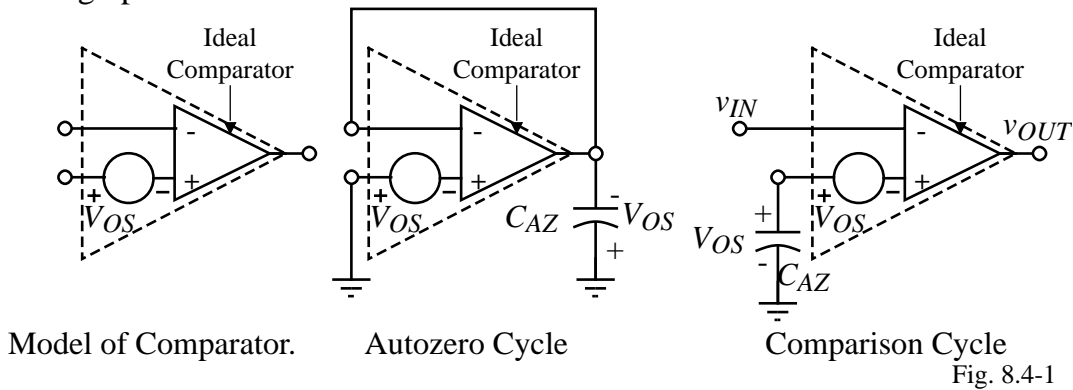

Comments:

- The comparator must be stable in the unity-gain mode (self-compensating comparators are good, the two-stage op comparator would require compensation to be switched in during the autozero cycle.)
- Complete offset cancellation is limited by charge injection

Differential Implementation of Autozeroed Comparators

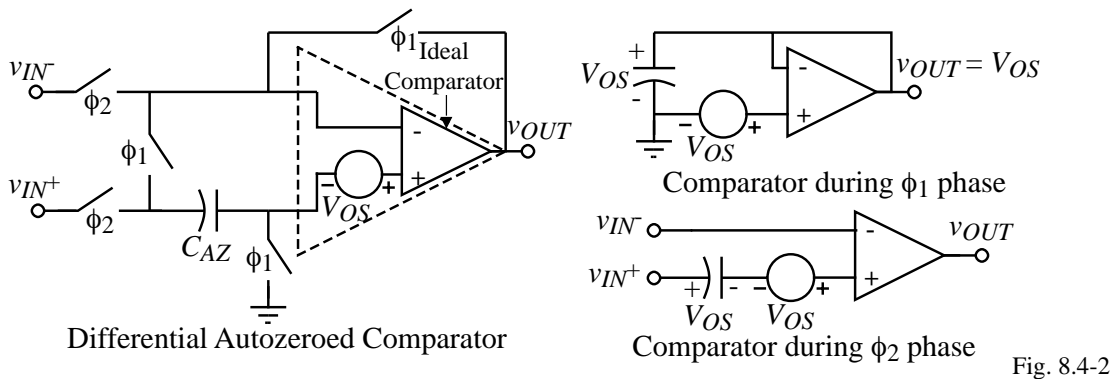

Single-Ended Autozeroed Comparators

Noninverting:

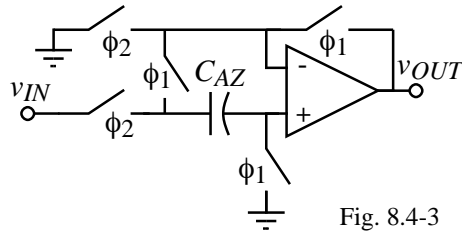

Fig. 8.4-3

Inverting:

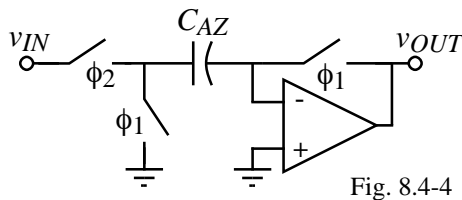

Fig. 8.4-4

Comment on autozeroing:

Need to be careful about noise that gets sampled onto the autozeroing capacitor and is present on the comparison phase of the process.

Influence of Input Noise on the Comparator

Comparator without hysteresis:

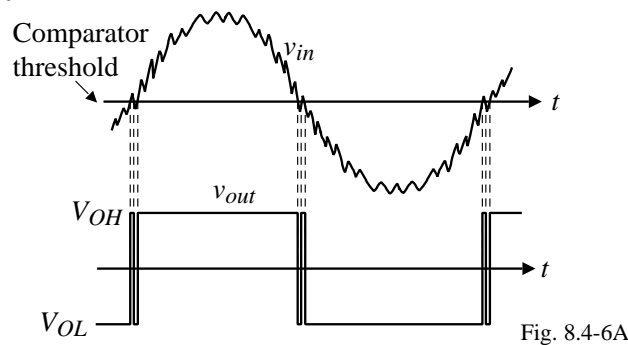

Fig. 8.4-6A

Comparator with hysteresis:

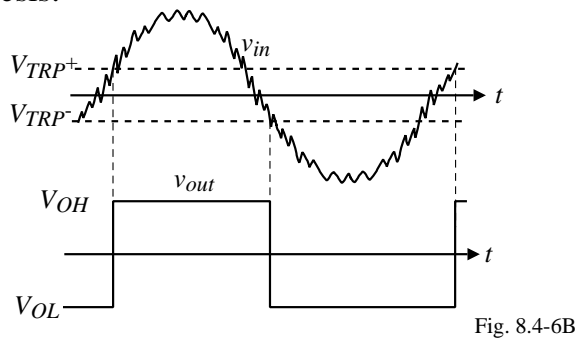
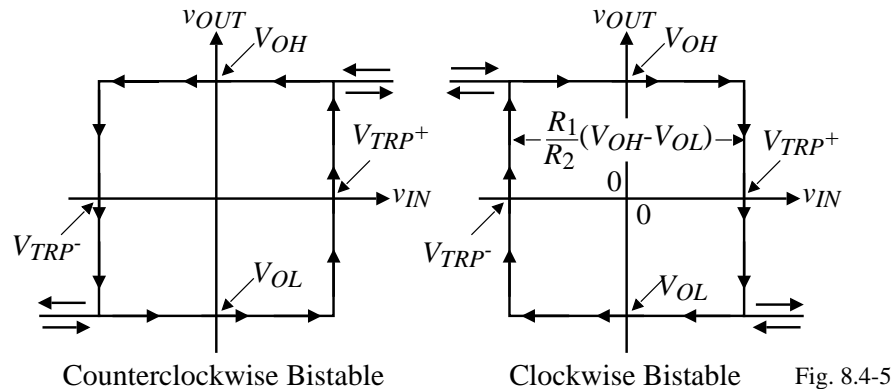

Fig. 8.4-6B

Use of Hysteresis for Comparators in a Noisy Environment

Transfer curve of a comparator with hysteresis:



Hysteresis is achieved by the use of positive feedback

- Externally
- Internally

Noninverting Comparator using External Positive Feedback

Circuit:

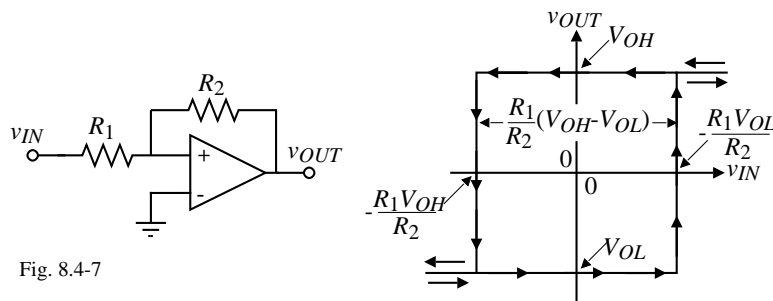

Upper Trip Point:

Assume that $v_{OUT} = V_{OL}$, the upper trip point occurs when,

$$0 = \left(\frac{R_1}{R_1+R_2}\right)V_{OL} + \left(\frac{R_2}{R_1+R_2}\right)V_{TRP+} \quad \rightarrow \quad V_{TRP+} = -\frac{R_1}{R_2}V_{OL}$$

Lower Trip Point:

Assume that $v_{OUT} = V_{OH}$, the lower trip point occurs when,

$$0 = \left(\frac{R_1}{R_1+R_2}\right)V_{OH} + \left(\frac{R_2}{R_1+R_2}\right)V_{TRP-} \quad \rightarrow \quad V_{TRP-} = -\frac{R_1}{R_2}V_{OH}$$

Width of the bistable characteristic:

$$\Delta V_{in} = V_{TRP+} - V_{TRP-} = \left(\frac{R_1}{R_2}\right)(V_{OH} - V_{OL})$$

Inverting Comparator using External Positive Feedback

Circuit:

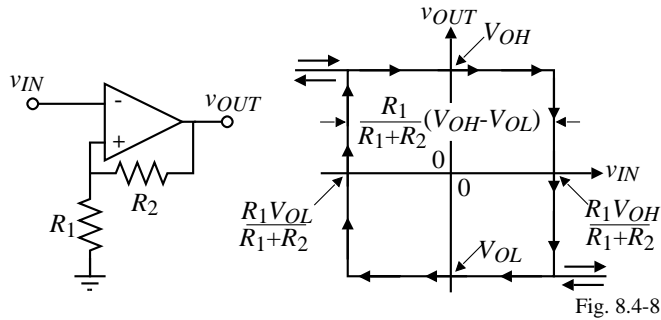

Fig. 8.4-8

Upper Trip Point:

$$v_{IN} = V_{TRP^+} = \left(\frac{R_1}{R_1 + R_2} \right) V_{OH}$$

Lower Trip Point:

$$v_{IN} = V_{TRP^-} = \left(\frac{R_1}{R_1 + R_2} \right) V_{OL}$$

Width of the bistable characteristic:

$$\Delta V_{in} = V_{TRP^+} - V_{TRP^-} = \left(\frac{R_1}{R_1 + R_2} \right) (V_{OH} - V_{OL})$$

Horizontal Shifting of the CCW Bistable Characteristic

Circuit:

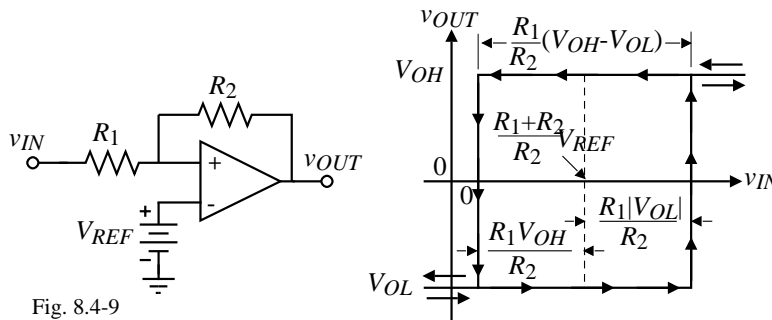

Fig. 8.4-9

Upper Trip Point:

$$V_{REF} = \left(\frac{R_1}{R_1 + R_2} \right) V_{OL} + \left(\frac{R_2}{R_1 + R_2} \right) V_{TRP^+} \quad \rightarrow \quad V_{TRP^+} = \left(\frac{R_1 + R_2}{R_2} \right) V_{REF} - \frac{R_1}{R_2} V_{OL}$$

Lower Trip Point:

$$V_{REF} = \left(\frac{R_1}{R_1 + R_2} \right) V_{OH} + \left(\frac{R_2}{R_1 + R_2} \right) V_{TRP^-} \quad \rightarrow \quad V_{TRP^-} = \left(\frac{R_1 + R_2}{R_2} \right) V_{REF} - \frac{R_1}{R_2} V_{OH}$$

Shifting Factor: $\left(\frac{R_1 + R_2}{R_2} \right) V_{REF}$

Horizontal Shifting of the CW Bistable Characteristic

Circuit:

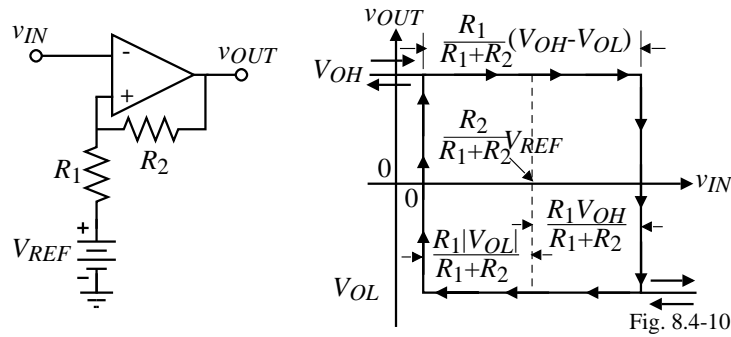

Upper Trip Point:

$$v_{IN} = V_{TRP}^+ = \left(\frac{R_1}{R_1+R_2} \right) V_{OH} + \left(\frac{R_2}{R_1+R_2} \right) V_{REF}$$

Lower Trip Point:

$$v_{IN} = V_{TRP}^- = \left(\frac{R_1}{R_1+R_2} \right) V_{OL} + \left(\frac{R_2}{R_1+R_2} \right) V_{REF}$$

Shifting Factor:

$$\left(\frac{R_2}{R_1+R_2} \right) V_{REF}$$

Example 8.4-1 Design of an Inverting Comparator with Hysteresis

Use the inverting bistable to design a high-gain, open-loop comparator having an upper trip point of 1V and a lower trip point of 0V if $V_{OH} = 2V$ and $V_{OL} = -2V$.

Solution

Putting the values of this example into the above relationships gives

$$1 = \left(\frac{R_1}{R_1+R_2} \right) 2 + \left(\frac{R_2}{R_1+R_2} \right) V_{REF}$$

and

$$0 = \left(\frac{R_1}{R_1+R_2} \right) (-2) + \left(\frac{R_2}{R_1+R_2} \right) V_{REF}$$

Solving these two equations gives $3R_1 = R_2$ and $V_{REF} = (2/3)V$.

Hysteresis using Internal Positive Feedback

Simple comparator with internal positive feedback:

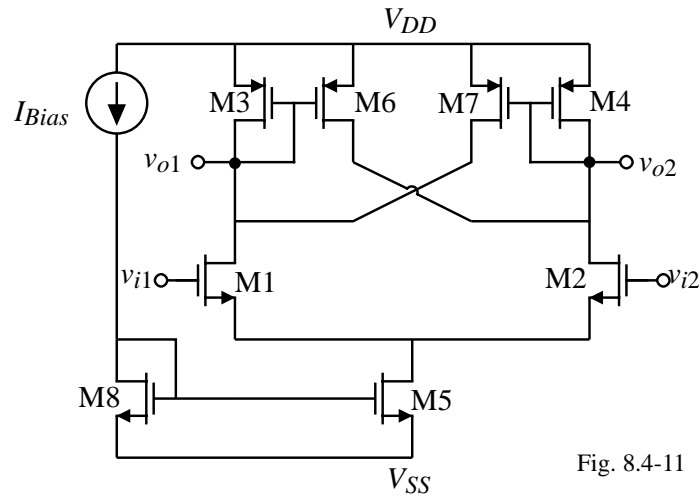

Fig. 8.4-11

Internal Positive Feedback - Upper Trip Point

Assume that the gate of M1 is on ground and the input to M2 is much smaller than zero. The resulting circuit is:

M1 on, M2 off → M3 and M6 on, M4 and M7 off.

∴ v_{o2} is high.

M6 would like to source the current $i_6 = \frac{W_6/L_6}{W_3/L_3} i_1$

As v_{in} begins to increase towards the trip point, the current flow through M2 increases. When $i_2 = i_6$, the upper trip point will occur.

$$\therefore i_5 = i_1 + i_2 = i_3 + i_6 = i_3 + \left(\frac{W_6/L_6}{W_3/L_3}\right) i_3 = i_3 \left[1 + \frac{W_6/L_6}{W_3/L_3}\right] \rightarrow i_1 = i_3 = \frac{i_5}{1 + [(W_6/L_6)/(W_3/L_3)]}$$

Also, $i_2 = i_5 - i_1 = i_5 - i_3$

Knowing i_1 and i_2 allows the calculation of v_{GS1} and v_{GS2} which gives

$$V_{TRP}^+ = v_{GS2} - v_{GS1} = \sqrt{\frac{2i_2}{\beta_2}} + V_{T2} - \sqrt{\frac{2i_1}{\beta_1}} - V_{T1}$$

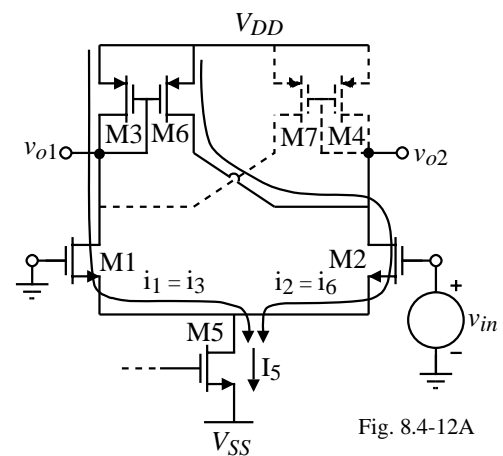

Fig. 8.4-12A

Internal Positive Feedback - Lower Trip Point

Assume that the gate of M1 is on ground and the input to M2 is much greater than zero. The resulting circuit is:

M2 on, M1 off → M4 and M7 on, M3 and M6 off.
 ∴ v_{o1} is high.

M7 would like to source the current $i_7 = \frac{W_7/L_7}{W_4/L_4} i_2$

As v_{in} begins to decrease towards the trip point, the current flow through M1 increases. When $i_1 = i_7$, the lower trip point will occur.

$$\therefore i_5 = i_1 + i_2 = i_7 + i_4 = \left(\frac{W_7/L_7}{W_4/L_4}\right)i_4 + i_4 = i_4 \left[1 + \frac{W_7/L_7}{W_4/L_4}\right] \rightarrow i_2 = i_4 = \frac{i_5}{1 + [(W_7/L_7)/(W_4/L_4)]}$$

Also, $i_1 = i_5 - i_2 = i_5 - i_4$

Knowing i_1 and i_2 allows the calculation of v_{GS1} and v_{GS2} which gives

$$V_{TRP^-} = v_{GS2} - v_{GS1} = \sqrt{\frac{2i_2}{\beta_2}} + V_{T2} - \sqrt{\frac{2i_1}{\beta_1}} - V_{T1}$$

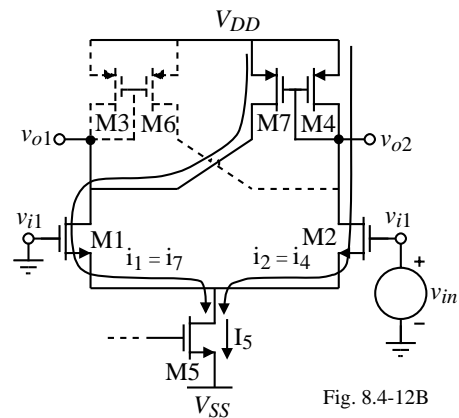

Fig. 8.4-12B

Example 8.4-2 - Calculation of Trip Voltages for a Comparator with Hysteresis

Consider the circuit shown. Using the transistor device parameters given in Table 3.1-2 calculate the positive and negative threshold points if the device lengths are all 1 μm and the widths are given as: $W_1 = W_2 = W_6 = W_7 = 10 \mu\text{m}$ and $W_3 = W_4 = 2 \mu\text{m}$. The gate of M1 is tied to ground and the input is the gate of M2. The current, $i_5 = 20 \mu\text{A}$

Solution

To calculate the positive trip point, assume that the input has been negative and is heading positive.

$$i_6 = \frac{(W/L)_6}{(W/L)_3} i_3 = (5/1)(i_3) \rightarrow i_3 = \frac{i_5}{1 + [(W/L)_6/(W/L)_3]} = i_1 = \frac{20 \mu\text{A}}{1 + 5} = 3.33 \mu\text{A}$$

$$i_2 = i_5 - i_1 = 20 - 3.33 = 16.67 \mu\text{A} \rightarrow v_{GS1} = \left(\frac{2i_1}{\beta_1}\right)^{1/2} + V_{T1} = \left(\frac{2 \cdot 3.33}{(5)110}\right)^{1/2} + 0.7 = 0.81\text{V}$$

$$v_{GS2} = \left(\frac{2i_2}{\beta_2}\right)^{1/2} + V_{T2} = \left(\frac{2 \cdot 16.67}{(5)110}\right)^{1/2} + 0.7 = 0.946\text{V}$$

$$\therefore V_{TRP+} \approx v_{GS2} - v_{GS1} = 0.946 - 0.810 = 0.136\text{V}$$

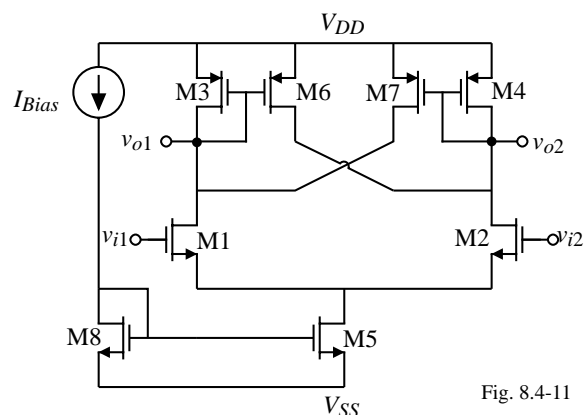

Fig. 8.4-11

Example 8.4-2 - Continued

Determining the negative trip point, similar analysis yields

$$i_4 = 3.33 \mu\text{A}$$

$$i_1 = 16.67 \mu\text{A}$$

$$v_{GS2} = 0.81\text{V}$$

$$v_{GS1} = 0.946\text{V}$$

$$V_{TRP-} \cong v_{GS2} - v_{GS1} = 0.81 - 0.946 = -0.136\text{V}$$

PSPICE simulation results of this circuit are shown below.

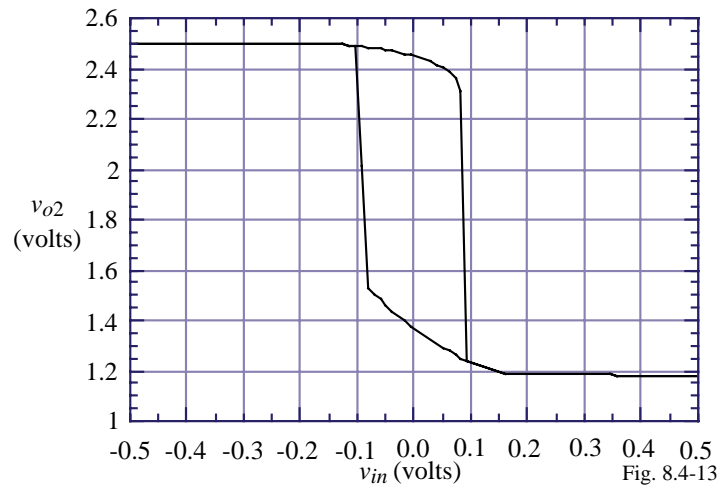
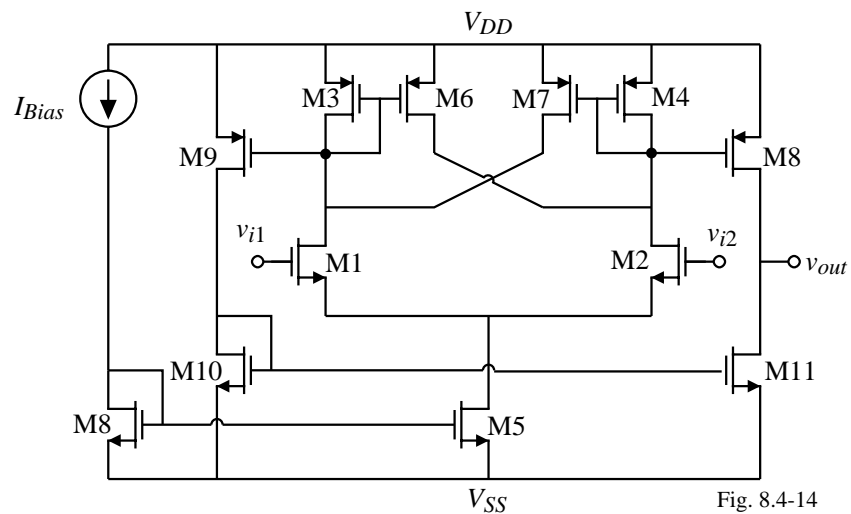
**Complete Comparator with Internal Hysteresis**

Schmitt Trigger

The Schmitt trigger is a circuit that has better defined switching points. Consider the following circuit:

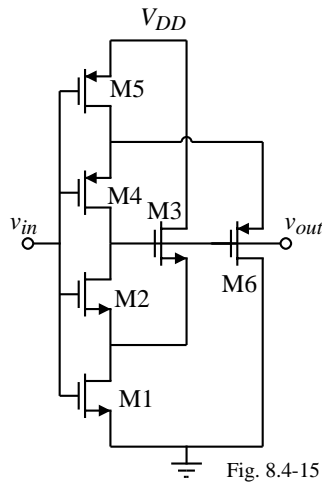

Fig. 8.4-15

How does this circuit work?

Assume the input voltage, v_{in} , is low and the output voltage, v_{out} , is high.

M3, M4 and M5 are on and M1, M2 and M6 are off.

When v_{in} is increased from zero, M2 starts to turn on causing M3 to start turning off. Positive feedback causes M2 to turn on further and eventually both M1 and M2 are on and the output is at zero.

The upper switching point, V_{TRP}^+ is found as follows:

When v_{in} is low, the voltage at the source of M2 (M3) is

$$v_{S2} = V_{DD} - V_{TN3}$$

$V_{TRP}^+ = v_{in}$ when M2 turns on given as $V_{TRP}^+ = V_{TN2} + v_{S2}$

V_{TRP}^+ occurs when the input voltage causes the currents in M3 and M1 to be equal.

Schmitt Trigger – Continued

Thus, $i_{D1} = \beta_1 (V_{TRP}^+ - V_{TN1})^2 = \beta_3 (V_{DD} - v_{S2} - V_{TN3})^2 = i_{D3}$
which can be written as, assuming that $V_{TN2} = V_{TN3}$,

$$\beta_1 (V_{TRP}^+ - V_{TN1})^2 = \beta_3 (V_{DD} - V_{TRP}^+)^2 \Rightarrow V_{TRP}^+ = \frac{V_{TN1} + \sqrt{\beta_3/\beta_1} V_{DD}}{1 + \sqrt{\beta_3/\beta_1}}$$

The switching point, V_{TRP}^- is found in a similar manner and is:

$$\beta_5 (V_{DD} - V_{TRP}^- - V_{TP5})^2 = \beta_6 (V_{TRP}^-)^2 \Rightarrow V_{TRP}^- = \frac{\sqrt{\beta_5/\beta_6} (V_{DD} - V_{TP5})}{1 + \sqrt{\beta_5/\beta_6}}$$

The bistable characteristic is,

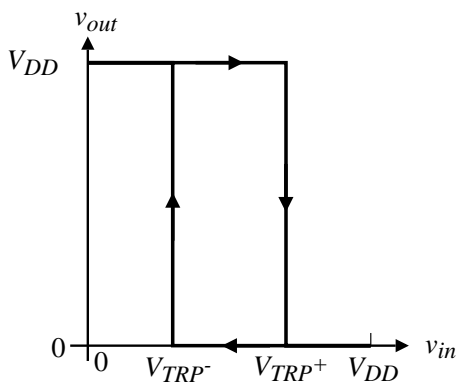

Fig. 8.4-16

SUMMARY

- Open-loop, continuous-time comparators can be improved in the areas of:
 - Current sinking and sourcing
 - Removal of offset voltages
 - Removal of the influence of a noisy signal through hysteresis
- Comparators with hysteresis (positive feedback)
 - External
 - Internal

SECTION 8.5 – DISCRETE-TIME COMPARATORS (LATCHES)

Objective

The objective of this section is:

- 1.) Illustrate discrete-time comparators
- 2.) Estimate the propagation delay time

Outline

- Switched capacitor comparators
- Regenerative comparators (latches)
- Summary

A Differential Switched Capacitor Comparator Avoiding Common Mode Problems

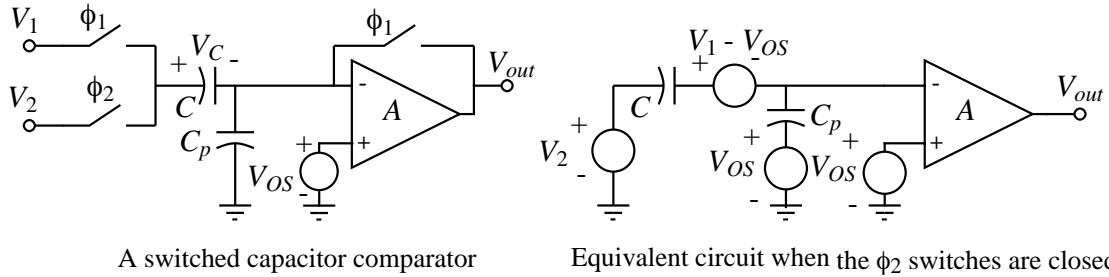

Fig. 8.5-1

ϕ_1 Phase:

The V_1 input is sampled and the dc input offset voltage is autozeroed.

$$V_C(\phi_1) = V_1 - V_{OS} \quad \text{and} \quad V_{Cp}(\phi_1) = V_{OS}$$

ϕ_2 Phase:

$$V_{out}(\phi_2) = -A \left[\frac{V_2 C}{C+C_p} - \frac{(V_1 - V_{OS})C}{C+C_p} + \frac{V_{OS} C_p}{C+C_p} \right] + AV_{OS}$$

$$= -A \left[(V_2 - V_1) \frac{C}{C+C_p} + V_{OS} \left(\frac{C}{C+C_p} + \frac{C_p}{C+C_p} \right) \right] + AV_{OS} = -A(V_2 - V_1) \frac{C}{C+C_p} \approx A(V_1 - V_2)$$

if C_p is smaller than C .

Differential-In, Differential-Out Switched Capacitor Comparator

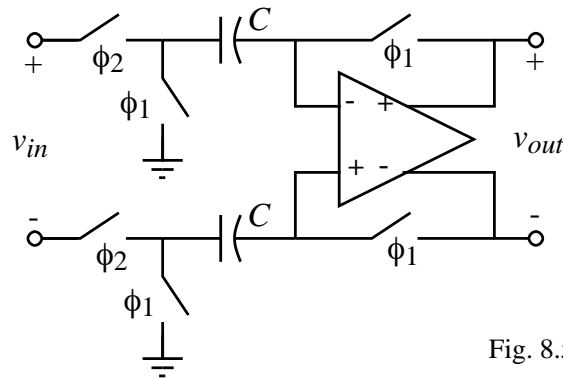

Fig. 8.5-2

Comments:

- Reduces the influence of charge injection
- Eliminates even harmonics

Regenerative Comparators

Regenerative comparators use positive feedback to accomplish the comparison of two signals. Latches have a faster switching speed than the previous bistable comparators. NMOS and PMOS latch:

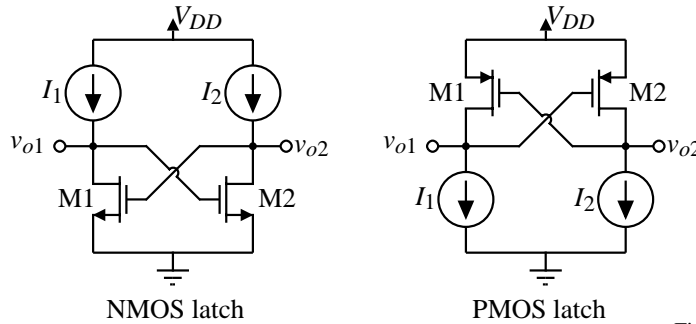

Fig. 8.5-3

How is the input applied to a latch?

The inputs are initially applied to the outputs of the latch.

V_{o1}' = initial input applied to v_{o1}

V_{o2}' = initial input applied to v_{o2}

Step Response of a Latch

Circuit:

R_i and C_i are the resistance and capacitance seen to ground from the i -th transistor.

Nodal equations:

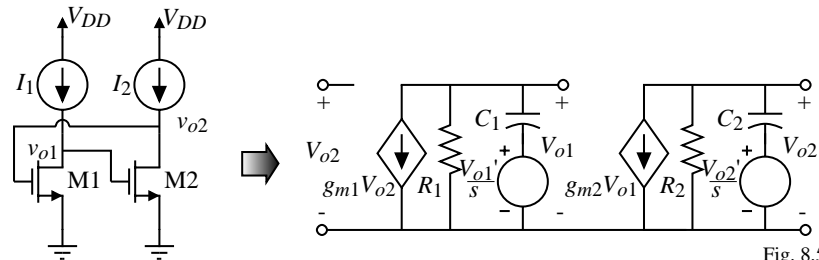

Fig. 8.5-4

$$g_{m1}V_{o2} + G_1V_{o1} + sC_1\left(V_{o1} - \frac{V_{o1}'}{s}\right) = g_{m1}V_{o2} + G_1V_{o1} + sC_1V_{o1} - C_1V_{o1}' = 0$$

$$g_{m2}V_{o1} + G_2V_{o2} + sC_2\left(V_{o2} - \frac{V_{o2}'}{s}\right) = g_{m2}V_{o1} + G_2V_{o2} + sC_2V_{o2} - C_2V_{o2}' = 0$$

Solving for V_{o1} and V_{o2} gives,

$$V_{o1} = \frac{R_1C_1}{sR_1C_1+1}V_{o1}' - \frac{g_{m1}R_1}{sR_1C_1+1}V_{o2} = \frac{\tau_1}{s\tau_1+1}V_{o1}' - \frac{g_{m1}R_1}{s\tau_1+1}V_{o2}$$

$$V_{o2} = \frac{R_2C_2}{sR_2C_2+1}V_{o2}' - \frac{g_{m2}R_2}{sR_2C_2+1}V_{o1} = \frac{\tau_2}{s\tau_2+1}V_{o2}' - \frac{g_{m2}R_2}{s\tau_2+1}V_{o1}$$

Defining the output, ΔV_o , and input, ΔV_i , as

$$\Delta V_o = V_{o2} - V_{o1} \quad \text{and} \quad \Delta V_i = V_{o2}' - V_{o1}'$$

Step Response of the Latch - Continued

Solving for ΔV_o gives,

$$\Delta V_o = V_{o2} - V_{o1} = \frac{\tau}{s\tau + 1} \Delta V_i + \frac{g_m R}{s\tau + 1} \Delta V_o$$

or

$$\Delta V_o = \frac{\tau \Delta V_i}{s\tau + (1 - g_m R)} = \frac{\frac{\tau \Delta V_i}{1 - g_m R}}{\frac{s\tau}{1 - g_m R} + 1} = \frac{\tau' \Delta V_i}{s\tau' + 1}$$

where

$$\tau' = \frac{\tau}{1 - g_m R}$$

Taking the inverse Laplace transform gives

$$\Delta v_o(t) = \Delta V_i e^{-t/\tau'} = \Delta V_i e^{-t(1 - g_m R)/\tau} \approx e^{g_m R t/\tau} \Delta V_i, \quad \text{if } g_m R \gg 1.$$

Define the latch time constant as

$$\tau_L = |\tau'| \approx \frac{\tau}{g_m R} = \frac{C}{g_m} = \frac{0.67 W L C_{ox}}{\sqrt{2K'(W/L)I}} = 0.67 C_{ox} \sqrt{\frac{W L^3}{2K'I}}$$

if $C \approx C_{gs}$.

$$\therefore \Delta V_{out}(t) = e^{t/\tau_L} \Delta V_i$$

Step Response of a Latch - Continued

Normalize the output voltage by $(V_{OH} - V_{OL})$ to get

$$\frac{\Delta V_{out}(t)}{V_{OH} - V_{OL}} = e^{t/\tau_L} \frac{\Delta V_i}{V_{OH} - V_{OL}}$$

which is plotted as,

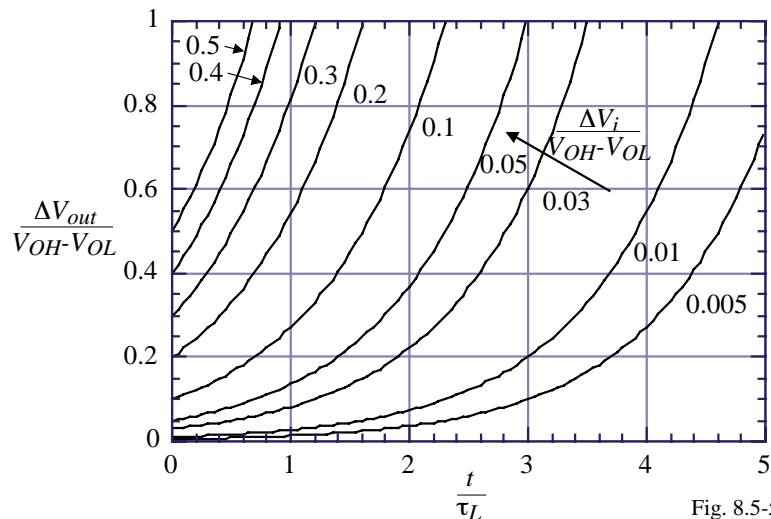

Fig. 8.5-5

The propagation delay time is $t_p = \tau_L \ln \left(\frac{V_{OH} - V_{OL}}{2\Delta V_i} \right)$

Example 8.5-1 - Time domain characteristics of a latch.

Find the time it takes from the time the latch is enabled until the output voltage, ΔV_{out} , equals $V_{OH}-V_{OL}$ if the W/L of the latch NMOS transistors is $10\mu\text{m}/1\mu\text{m}$ and the latch dc current is $10\mu\text{A}$ when $\Delta V_i = 0.1(V_{OH}-V_{OL})$ and $\Delta V_i = 0.01(V_{OH}-V_{OL})$. Find the propagation time delay ($\Delta V_{out}=0.5(V_{OH}-V_{OL})$) for the latch for each of these conditions.

Solution

The transconductance of the latch transistors is

$$g_m = \sqrt{2 \cdot 110 \cdot 10 \cdot 10} = 148 \mu\text{S}$$

The output conductance is $0.4\mu\text{S}$ which gives $g_m R$ of 370V/V . Since $g_m R$ is greater than 1, we can use the above results. Therefore the latch time constant is found as

$$\tau_L = 0.67 C_{ox} \sqrt{\frac{WL^3}{2KI}} = 0.67(24 \times 10^{-4}) \sqrt{\frac{(10 \cdot 1) \times 10^{-18}}{2 \cdot 110 \times 10^{-6} \cdot 10 \times 10^{-6}}} = 108 \text{ns}$$

If we assume that the propagation time delay is the time for the output to reach $(V_{OH}-V_{OL})$, then for $\Delta V_i = 0.01(V_{OH}-V_{OL})$ that $t_p = 4.602\tau_L = 497\text{ns}$ and for $\Delta V_i = 0.1(V_{OH}-V_{OL})$ that $t_p = 2.306\tau_L = 249\text{ns}$.

If we assume that the propagation time delay is the time when the output is $0.5(V_{OH}-V_{OL})$, then using the above results or Fig. 8.5-5 we find for $\Delta V_i = 0.01(V_{OH}-V_{OL})$ that $t_p = 3.91\tau_L = 422\text{ns}$ and for $\Delta V_i = 0.1(V_{OH}-V_{OL})$ that $t_p = 1.61\tau_L = 174\text{ns}$.

Comparator using a Latch with a Built-In Threshold[†]

How does it operate?

- 1.) Devices in shaded region operate in the triode region.
- 2.) When the latch/reset goes high, the upper cross-coupled inverter-latch regenerates. The drain currents of M5 and M6 are steered to obtain a final state determined by the mismatch between the R_1 and R_2 resistances.

$$\frac{1}{R_1} = K_N \left[\frac{W_1}{L} (v_{in}^+ - V_T) + \frac{W_2}{L} (V_{REF}^- - V_T) \right]$$

and

$$\frac{1}{R_2} = K_N \left[\frac{W_1}{L} (v_{in}^- - V_T) + \frac{W_2}{L} (V_{REF}^+ - V_T) \right]$$

- 3.) The input voltage which causes $R_1 = R_2$ is $v_{in}(\text{threshold}) = (W_2/W_1)V_{REF}$
 $W_2/W_1 = 1/4$ generates a threshold of $\pm 0.25V_{REF}$.

Performance \rightarrow 20Ms/s & $200\mu\text{W}$

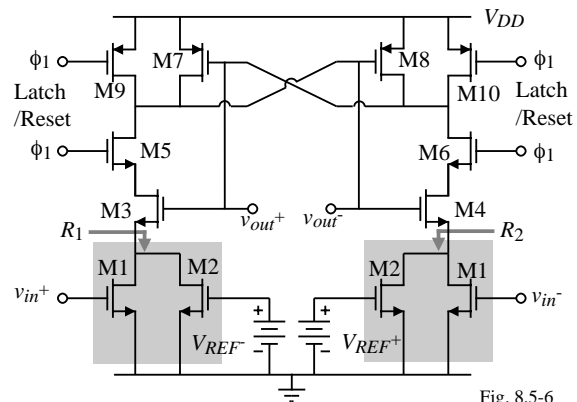

Fig. 8.5-6

[†] T.B. Cho and P.R. Gray, "A 10b, 20Msamples/s, 35mW pipeline A/D Converter," *IEEE J. Solid-State Circuits*, vol. 30, no. 3, pp. 166-172, March 1995.

Simple, Low Power Latched Comparator[†]

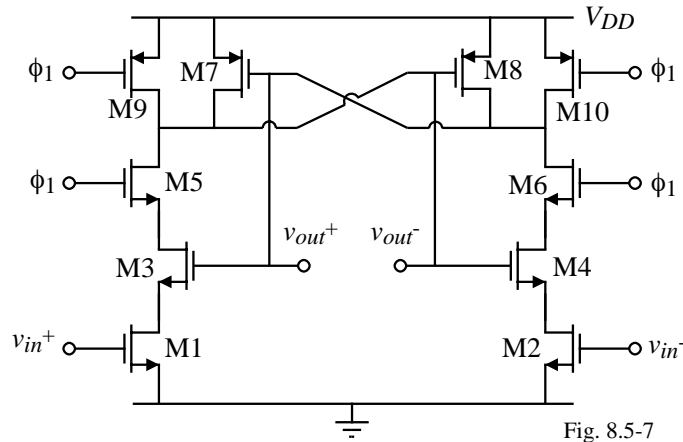

Fig. 8.5-7

Dissipated $50\mu\text{W}$ when clocked at 2MHz.

[†] A. Coban, "1.5V, 1mW, 98-dB Delta-Sigma ADC", Ph.D. dissertation, School of ECE, Georgia Tech, Atlanta, GA 30332-0250.

Dynamic Latch

Circuit:

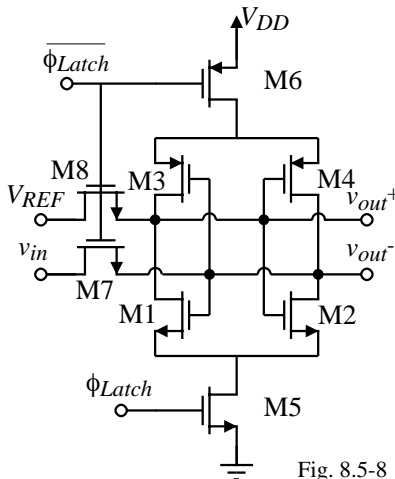

Fig. 8.5-8

Input offset voltage distribution:

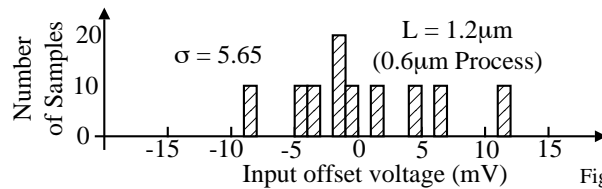

Fig. 8.5-9

Power dissipation/sampling rate = $4.3\mu\text{W}/\text{Ms/s}$

SUMMARY

- Discrete-time comparators must work with clocks
- Switched capacitor comparators use op amps to transfer charge and autozero
- Regenerative comparators (latches) use positive feedback
- The propagation delay of the regenerative comparator is slow at the beginning and speeds up rapidly as time increases
- The highest speed comparators will use a combination of open-loop comparators and latches

SECTION 8.6 – HIGH-SPEED COMPARATORS

Objective

The objective of this presentation is:

- 1.) Show how to achieve high-speed comparators

Outline

- Concepts of high-speed comparators
- Amplifier-latch comparators
- Summary

Conceptual Illustration of a Cascaded Comparator

How does a cascaded, high-speed comparator work?

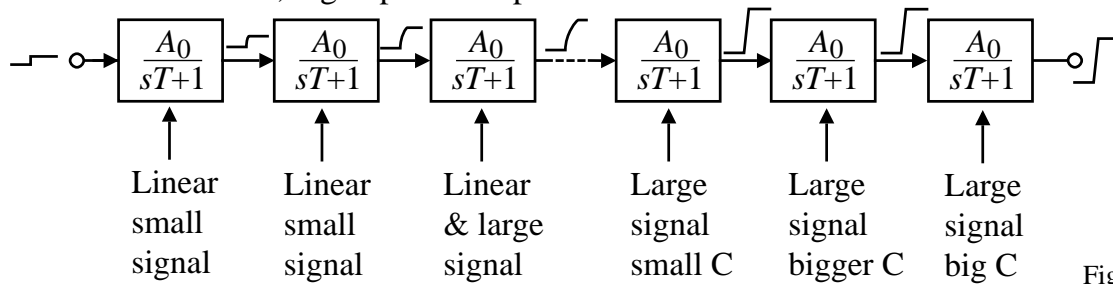

Fig. 8.6-1

Assuming a small overdrive,

- 1.) The initial stage build the driving capability.
- 2.) The latter stages swing rail-to-rail and build the ability to quickly charge and discharge capacitance.

Minimizing the Propagation Delay Time in Comparators

Fact:

- The input signal is equal to $V_{in}(\min)$ for worst case
- Amplifiers have a step response with a negative argument in the exponential
- Latches have a step response with a positive argument in the exponential

Result:

Use a cascade of linear amplifier to quickly build up the signal level and apply this amplified signal level to a latch for quick transition to the full binary output swing.

Illustration of a preamplifier and latch cascade:

Minimization of t_p :

Q. If the preamplifier consists of n stages of gain A having a single-pole response, what is the value of n and A that gives minimum propagation delay time?

A. $n = 6$ and $A = 2.62$ but this is a very broad minimum and n is usually 3 and $A \approx 6-7$ to save area.

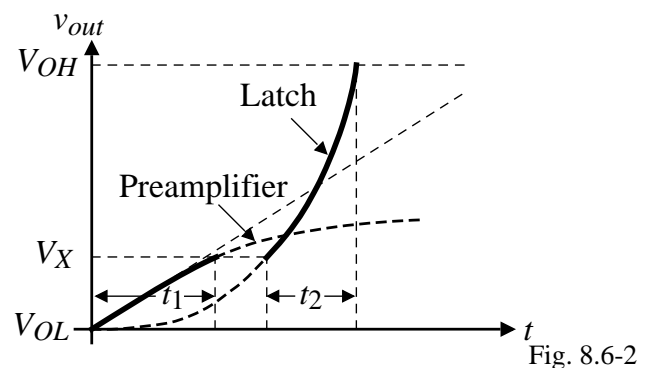

Fig. 8.6-2

Fully Differential, Three-Stage Amplifier and Latch Comparator

Circuit:

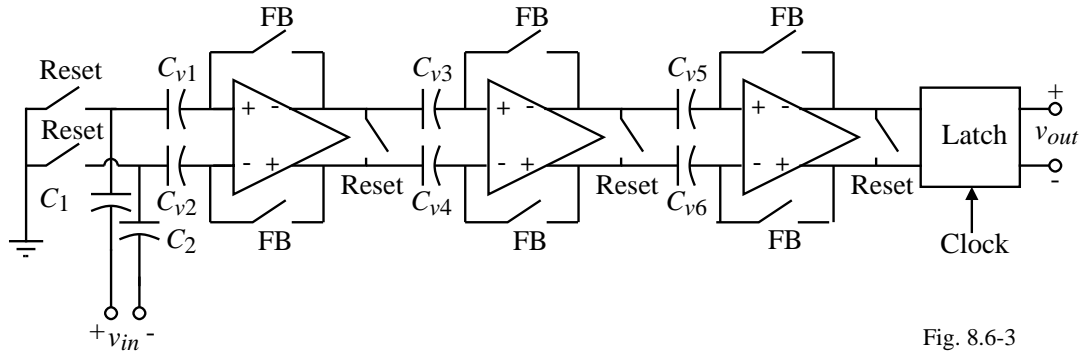

Fig. 8.6-3

Comments:

- Autozero and reset phase followed by comparison phase
- More switches are needed to accomplish the reset and autozero of all preamplifiers simultaneously
- Can run as high as 100Msps

Preamplifier and Latch Circuits

Gain:

$$A_v = -\frac{g_{m1}}{g_{m3}} = -\frac{g_{m2}}{g_{m4}} = -\sqrt{\frac{K_N'(W_1/L_1)}{K_P'(W_3/L_3)}}$$

Dominant Pole:

$$|p_{\text{dominant}}| = \frac{g_{m3}}{C} = \frac{g_{m4}}{C}$$

where C is the capacitance seen from the output nodes to ground.

If $(W_1/L_1)/(W_3/L_3) = 100$ and the bias current is $100\mu\text{A}$, then $A = -3.85$ and the bandwidth is 15.9MHz if $C = 0.5\text{pF}$.

Comments:

- If a buffer is used to reduce the output capacitance, one must take into account the loss of the buffer.
- The use of a preamplifier before the latch reduces the latch offset by the gain of the preamplifier so that the offset is due to the preamplifier only.

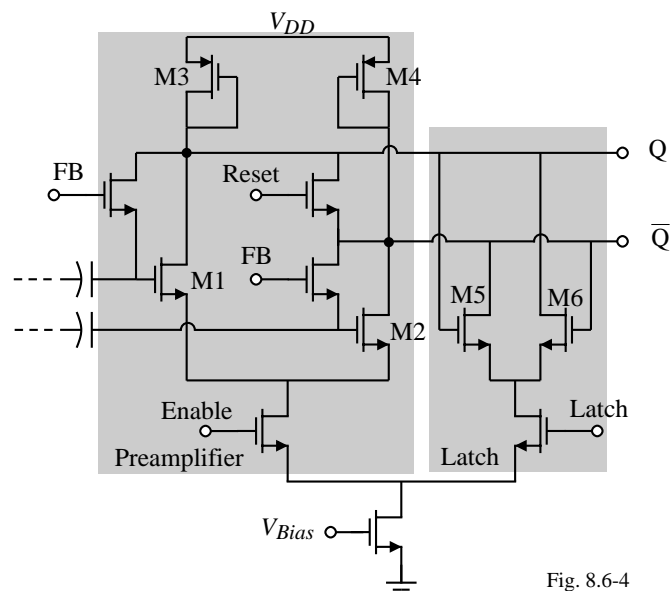

Fig. 8.6-4

An Improved Preamplifier

Circuit:

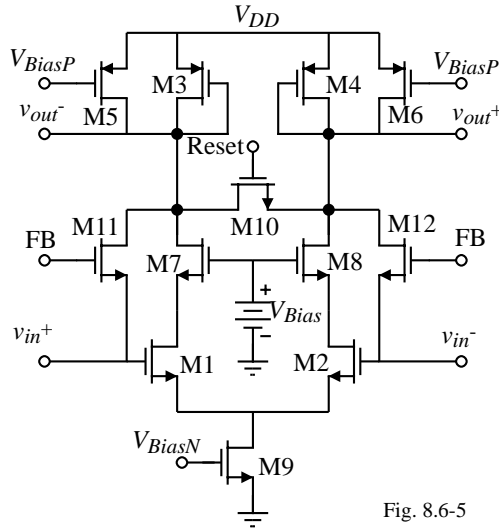

Fig. 8.6-5

Gain:

$$A_v = -\frac{g_{m1}}{g_{m3}} = -\sqrt{\frac{K_N'(W_1/L_1)I_1}{K_P'(W_3/L_3)I_3}} = -\sqrt{\frac{K_N'(W_1/L_1)}{K_P'(W_3/L_3)}} \sqrt{\frac{I_5}{1+I_3}}$$

If $I_5 = 24I_3$, the gain is increased by a factor of 5

Charge Transfer Preamplifier

The preamplifier can be replaced by the charge transfer circuit shown.

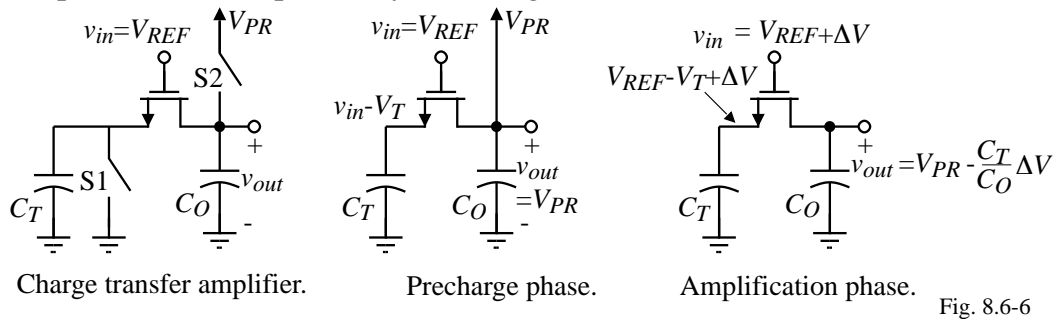

Fig. 8.6-6

Comments:

- Only positive values of voltage will be amplified.
- Large offset voltages result as a function of the subthreshold current.

CHAPTER 8 - SUMMARY

Types of Comparators Presented

- High-gain, open-loop
- Improved high-gain, open-loop, comparators
 - Hysteresis
 - Autozeroing
- Regenerative comparators
- Discrete-time comparators

Performance Characterization

- Propagation delay time
- Binary output swing
- Input resolution and/or gain
- Input offset voltage
- Power dissipation

Important Principles

- The speed of the comparator depends on the linear and slewing responses
- The dc input offset voltage depends on the matching and is reduced by autozeroing.
 - Charge injection is the limit of autozeroing
- The comparator gain should be large enough for a binary output when $v_{in} = V_{in}(\min)$
- Cascaded comparators, the first stages should large GB and the last stages high SR